

# UNICOL<sup>®</sup>

SPRING EDITION 61



## PROFESSIONAL AV MOUNTS

*Summit™ Video Conference Walls*  
page 32



*Screen Suspension Trade Pack*  
(KP110DB) - page 18



*Axia® Stands & Trolleys*  
(AX15T) - pages 8-9

*Sound & Video Bar Mounts*  
(SBM1) - pages 30-31

*Floor-to-Ceiling Kits*  
(FCGSH10) - page 19



*AV Media Cabinets*  
(AVRTHD3) - page 49

*Tap.IT™ Touch Panel Stands*  
(TBMP1) - page 33





## Another iconic year

In 2023 we celebrated our 60th anniversary - not only a milestone in the world of AV but significant in UNICOL being such a long established manufacturer of entirely British made products. Alongside our ever expanding range of catalogue items, UNICOL's long experienced design team is privileged to be involved with many diverse projects in support of the AV industry, with some of a more technically complex nature giving our design team much satisfaction in resolving.

This year marks the unveiling of an entirely redesigned 2024 catalogue style. Each range of products set out for maximum clarity and ease of reference, with the centre fold detailing all the basic assembly components available. For AV integrators, long established or new customers alike, UNICOL provides the 'go to' source for every kind of AV hardware need, including stands, trolleys or mounts, AV furniture, one off or larger scale special projects and more.

Welcome to UNICOL!

+44 (0)1865 767676 | sales@unicol.com | unicol.com

UNICOL Engineering, Green Road, Oxford, OX3 8EU

# Welcome to the Spring Catalogue

<b>Stands &amp; Trolleys</b>	<b>6 - 17</b>	<b>Tap.IT™ Touch Panel Mounts ★</b>	<b>55</b>
VS1000® Stands, Trolleys & Components	6-7	<b>Digital Signage</b>	<b>54- 41</b>
Axia® Stands & Trolleys ★	8-9	Obelisk™ Kiosks & Totems ★	34-35
Avecta® Stands & Trolleys	10-11	EdgeLine™ Kiosks & Totems ★	36-37
Parabella® Stands	12	Outdoor Housings ★	38
Tevella™ Stands ★	12	Front & Rear Protective Covers ★	39
Nest-Star® Nesting Trolleys	13	Gantry Systems	40
Tableau™ Lectern Stands & Trolleys	13	AV Roller Trak™	41
Rhobus® Stands & Trolleys ★	14-15	<b>LED Solutions</b>	<b>42 - 45</b>
Rhobus® Lite Stands & Trolleys ★	16	Dedicated LED Mounts ★	42
Axia® Titan Heavy Duty Stands & Trolleys	16	All-in-One Mounts ★	43
PowaLift™ Motorised Stands & Trolleys ★	17	<b>Mobile Phone Holders ★</b>	<b>45</b>
<b>Trade Packs</b>	<b>18 - 21</b>	<b>Video Wall</b>	<b>44 - 45</b>
Screen Suspension Kits ★	18	Adapta-Wall® Pop-Out Video Wall Mounts	44
Floor-to-Ceiling Kits ★	19	Pop-Out Video Wall Structures	45
Floor-to-Wall Kits ★	19	V-Wall™ Video Wall Stand	45
ScreenRail™ Multi-Display System ★	20	<b>AV Furniture</b>	<b>46 - 49</b>
ScreenRail™ Menu Board & Video Wall Kits	21	Table Stands ★	46
<b>Wall Mounts</b>	<b>22 - 27</b>	Rhobus® Huddle Collaborative Tables	46
Xactmatch™ Dedicated Wall Mounts	22	Canterbury™ Freestanding Lectern	47
Rota-Mount™ Rotating Mounts	22	Presenter™ Wall Mounted Lectern	47
Pozimount® Universal Wall Mounts	23	Principal™ Lecturer's Desks	48
Universal Slim Profile Mounts	23	Mentor™ Lecturer's Desks	48
Universal Small Screen Mounts	24	AV Media Cabinets ★	49
Accession™ Service Mounts ★	24	<b>Projector Mounts</b>	<b>50 - 53</b>
VertiSlide™ Serviceable Cassette Mounts	25	Projector Suspension Units (PSU™)	50
Panarm™ Articulated Wall Arms ★	26	Guardbox® Security Cages	51
Wall Arms	27	Gyrolock® Projector Mounts ★	52-53
Universal PC Housings	27	<b>Single Column Solutions</b>	<b>54</b>
<b>Installation Components ★</b>	<b>28 - 29</b>	<b>Small Parts &amp; Accessories</b>	<b>55</b>
<b>Sound Bar, Video Bar &amp; Video Conference Mounts ★</b>	<b>30 - 31</b>		
<b>Speaker Mounts ★</b>	<b>31</b>		
<b>Summit™ Video Conference Walls ★</b>	<b>32</b>		

★ page features new products

All goods are sold subject to the Companies terms & conditions of sale, a copy of which is available upon request or can be downloaded from our website unicol.com. VAT will be charged at the prevailing rate at time of invoice. Mechanical items have a 10 year design & manufacturing warranty. Electrical parts are covered by a 12 month return to base warranty. UNICOL products are the subject of continuous development and we reserve the right to improve designs or change specifications without prior notice. © Peter Ligertwood 2024.

# NEW! Accession™ Service Mount

These pull-out serviceable mounts offer the ability to populate the perforated AV trays with a broad range of devices for a chosen installation, either on-site or remotely.

See page 24.

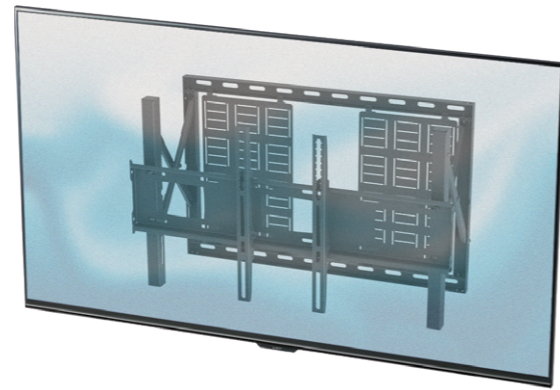

# NEW! Rhobus® Lite Stands & Trolleys

Slim-line version of the well-proven Rhobus® range. Accepts a wide variety of screen sizes with lockable equipment and cable management within mast. Convenient power cable input with built-in IEC socket.

See page 16.



# NEW! All-In-One LED Solutions

Dedicated to all-in-one screens from 110" up to 200" and available in floor-to-wall, floor-to-ceiling and ceiling suspended versions.

See page 43.

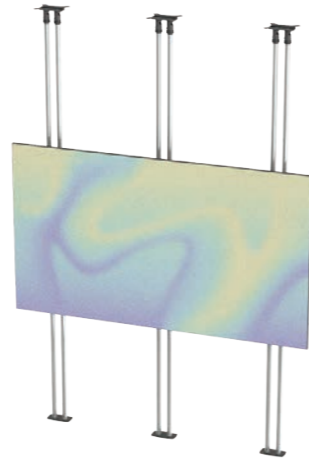

# NEW! Summit™ Video Conference Walls

Provides a neat and increasingly popular way of combining all the necessary elements of a video conferencing solution into a neat and aesthetic unit.

See page 32.



# NEW! LED Digital Signage Totems

Based on our well-proven EdgeLine™ range, these totems deliver an aesthetically pleasing solution. Each are designed to accommodate any desired array of LED tiles.

See page 37.

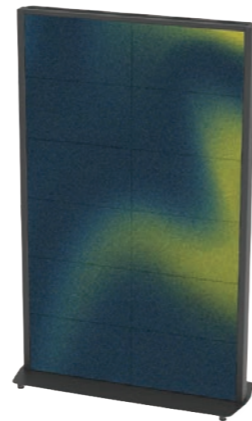

We understand that sometimes a mount can't be one size fits all, and occasionally you just need something a bit unique.

Whether that's designing a custom framework for an AV roll-out over multiple locations, or suspending LED video walls in unusual places, or even just adding a custom ticket scanner within a branded kiosk/totem, UNICOL's special project team are here to help.

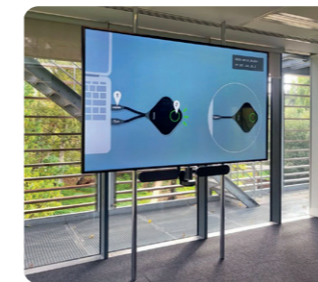

Floor-to-Ceiling Kits p.19



Tablet Mounts & Stands p.33



Photo: 21st Century AV  
LED Mounts p.42



Sound Bar Mounts p.30-31



Obelisk Totems p.34



Photo: GV AV Ltd.  
Nest-Star Trolleys p.13



Rhobus Stands p.15



Principal Desks p.48



Pop-Out Wall Mounts p.44

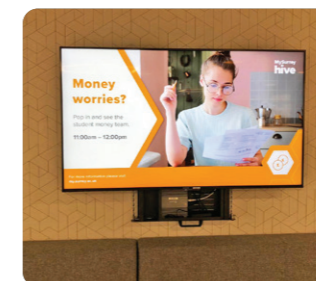

Serviceable Mounts p.25



ScreenRail Menu Board Kits p.21

Looking for other new products? **NEW products** are highlighted with **BLUE** throughout this catalogue

## Colour Finishes

Colours that are available at no extra cost are indicated on each product page. These colours typically consist of;

- Sinterflex Black
- Sinterflex White
- Diamond Silver
- Chrome (Columns Only)

Where a choice is shown, please state colour choice when ordering. Other colours are charged at +18% plus powder purchase cost.

Please note: all prices shown are ex-works and ex-VAT.

## Delivery & Collection

All orders can either be delivered to your chosen address, or collected from UNICOL, Green Road, Oxford, OX3 8EU.



British Design & Manufacturing



Europe: UNICOL Deutschland GmbH



Global Shipping Available



Rapid turnaround on projects



Large and small projects welcome



Manufactured & designed in-house



10 year warranty Design & Manufacture\*

Start your project today, call 01865 767676 or email [sales@unicol.com](mailto:sales@unicol.com)



## The Workhorse of the Industry

With a wide choice of interchangeable parts, easy assembly and sheer robustness VS1000® trolleys are the favoured choice of exhibitions, broadcast and AV users everywhere.

Available as static, wheeled base or back to back versions, with a wide choice of height options. Accessories include metal or glass shelves, locking cabinets and other options.

### Versatile, Stylish Trolley Base Options

The curved Scimitar base units offers an stylised alternative to the original 'K' base design.

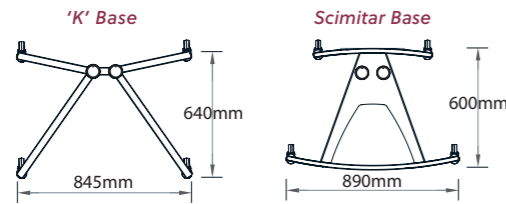

### Modular Connectivity for Custom Builds

UNICOL's modular style allows you to mix and match most components to create custom solutions to suit your requirements.

Use the table on the right to configure your own VS1000®



VS1000 K-Base Trolley (VSB-1500x20PS2-PZX)



Part Code & Description	Cost £ (Exc. VAT)	Dimensions (H x W x Dmm)	Weight	Screen Size	VESA Fixings	Weight Capacity	Colour
VSB-1500x2-VMSV   K Base Trolley w/VESA Mount	292.35	1640x870x600	19.1kg	15 - 32"	75x75 / 200x200	35kg	■
VSB-1500x2-VMSV2   K Base Trolley w/VESA Mount	303.05	1640x870x600	20.5kg	33 - 40"	300x300 / 400x400	40kg	■
VSB-1500x2-PS2-PZX   K Base Trolley w/Universal Mount	363.70	1640x870x600	26.8kg	33 - 70"	200x200 / 600x400	60kg	■
VSS-1500x2-VMSV   Scimitar Base Trolley w/VESA Mount	307.05	1680x890x660	24.6kg	15 - 32"	75x75 / 200x200	35kg	■
VSS-1500x2-VMSV2   Scimitar Base Trolley w/VESA Mount	317.75	1680x890x660	25.9kg	33 - 40"	300x300 / 400x400	40kg	■
VSS-1500x2-PS2-PZX   Scimitar Base Trolley w/Universal Mount	378.40	1680x890x660	29.7kg	33 - 70"	200x200 / 600x400	60kg	■
VSL-1500x2-PS2-PZX   Plinth Stand w/Universal Mount	384.30	1560x765x580	30.8kg	33 - 70"	200x200 / 600x400	60kg	■
VSF-1500x2-PS2-PZX   Bolt Down Stand w/Universal Mount	348.85	1525x765x300	20.3kg	33 - 70"	200x200 / 600x400	60kg	■
VSLBB-1500x2-PS8-PPZXx2   Plinth Base w/Back-to-Back Mount	634.30	1545x765x700	42.3kg	33 - 70"	200x200 / 600x400	35kg*	■
VSS-500x2-PS2VT-PZX   Scimitar Base Comfort Monitor Trolley	370.15	642x891x625	11.3kg	33 - 70"	200x200 / 600x400	60kg	■
TCAVT   Heavy Duty Trolley	698.20	1804x1075x694	49.0kg	71 - 110"	300x300 / 1000x600	120kg	■

\*max weight per screen

Product Image	Part Code & Description Specification	Cost £ (Exc. VAT)	Dimensions (H x W x Dmm)	Weight	Weight Capacity	Colour
	<b>PS2   Single Sided Twin Column Mount Adapter</b> Converts Pozimount or Xactmatch mounts to fit twin columns. Standard Allen screw fixing. Fully height adjustable.	59.75	180 x 180 x 130	2.3kg	80kg	■
	<b>PS8   Back-to-Back Twin Column Mount Adapter</b> Converts Pozimount or Xactmatch mounts to fit twin columns. Standard Allen screw fixing. Fully height adjustable.	85.00	180 x 180 x 100	3.1kg	80kg	■
	<b>PS2VT   Single Sided Tilting Twin Column Mount Adapter</b> Converts Pozimount or Xactmatch mounts to fit twin columns. Offers 0-55° tilt. For use with 500x2 columns only.	116.50	190-220 x 205 x 188-280	3.6kg	80kg	■
	<b>PZX1   Pozimount Universal Flat Screen Mount</b> For screens 33" to 70" and covers VESA fixings from 200x200 to 600x400.	98.40	540 x 765 x 45	5.5kg	60kg	■
	<b>PZX3   Pozimount Universal Flat Screen Mount</b> For screens 33" to 70" and covers VESA fixings from 200x200 to 400x400.	98.40	440 x 540 x 45	4.1kg	60kg	■
	<b>VMSV   Column Fitting VESA Mount (up to 32")</b> Fits direct to columns, covers 75x75 to 200x200 VESA fixings.	86.80	220 x 230 x 220	2.7kg	35kg	■
	<b>VMSV2   Column Fitting VESA Mount (up to 40")</b> Fits direct to columns, covers 300x300 to 400x400 VESA fixings.	97.50	420 x 440 x 220	4.1kg	40kg	■
	<b>1500x2   1500mm Pair of Chrome Column Lengths</b> UNICOL's signature chrome plate columns.	97.50	1500 x 50.8 x 50.8	5.5kg	n/a	●
	<b>500x2   500mm Pair of Chrome Column Lengths</b> UNICOL's signature chrome plate columns.	32.50	500 x 50.8 x 50.8	2.0kg	n/a	●
	<b>VSS   Scimitar Trolley Base (No Brakes)</b> Elegant curved design with 10cm non-marking rubber wheels.	122.75	280 x 890 x 660	16.4kg	80kg	■
	<b>VSR   Scimitar Trolley Base with Brakes</b> Elegant curved design with 10cm non-marking rubber wheels.	182.15	295 x 890 x 660	14.3kg	105kg	■
	<b>VSX   Scimitar Plinth Base</b> Elegant curved design with 1.5cm plastic feet.	103.20	180 x 890 x 660	11.3kg	80kg	■
	<b>VSB   Original 'K' Style Trolley Base (No Brakes)</b> Elegant curved design with 10cm non-marking rubber wheels.	108.05	255 x 870 x 600	10.9kg	80kg	■
	<b>VBR   Original 'K' Style with Brakes</b> Elegant curved design with 10cm non-marking rubber wheels.	167.45	240 x 870 x 600	9.0kg	105kg	■
	<b>VSL   Standard Plinth Base</b> Stylish curved edge base with resilient non-marking feet and clearance for cables underneath.	128.65	142 x 760 x 580	17.5kg	80kg	■
	<b>VSLBB   Back-to-Back Base</b> Features centralised column sockets for back-to-back screens. Resilient non-marking feet and has clearance for cables underneath.	255.00	142 x 700 x 700	22.6kg	80kg	■
	<b>VSF   Compact Bolt Down Base</b> Minimal base footprint for fixed screen stands. M10 bolts (not supplied) fully recess into base. Trim caps complete the installation.	93.20	160 x 400 x 300	7.0kg	80kg	■
	<b>VP1   500x400mm Metal Shelf</b> Ideal for holding small devices or notes in presentations.	61.50	125 x 500 x 450	5.1kg	20kg	■
	<b>VP2   550x450mm Metal Shelf</b> Ideal for holding small devices or notes in presentations.	69.50	125 x 550 x 500	6.0kg	20kg	■
	<b>VP3   300x300mm Metal Shelf</b> Ideal for holding small devices or notes in presentations.	54.20	125 x 300 x 360	2.9kg	20kg	■
	<b>VGS   500x400mm Toughened Glass Shelf</b> Ideal for holding small devices or notes in presentations.	78.80	125 x 500 x 480	5.6kg	20kg	■
	<b>VLC   Locking Cabinet - 150h x 550w x 450d mm Internal Dims</b> For small PC's, keyboards, DVD players and other small devices. Fully height adjustable. Rear panel offers cable access.	161.85	180 x 610 x 535	18.6kg	40kg	■
	<b>ESU   UK 4-Way Power Socket</b> Clips to the VS1000 base. 4m cable and 13A plug.	34.50	n/a	1.1kg	n/a	n/a
	<b>ESE   EU 4-Way Power Socket</b> Clips to the VS1000 base. 4m cable and 13A plug.	34.90	n/a	1.0kg	n/a	n/a



## The Practical Art-form

This Axia® range combines stylish design with practicality, featuring neat cable management, a built-in screen mount, and a 4-way power socket for seamless connectivity.

Safety glass shelves combine practicality and durability, while video conferencing and portrait screen options cater to the needs of the modern workplace.

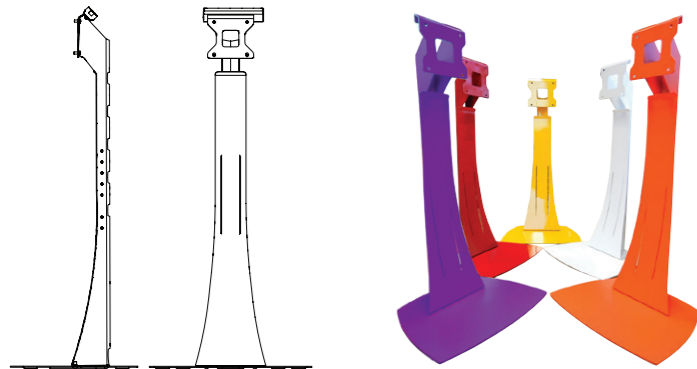

### Stylish Curved Mast with Neat Cable Management

With a graceful flowing curve, the Axia® offers a unique, stylish solution for corporate environments.

### Colour Options - Consistent with your Brand Guidelines

Corporate colours can enhance the stands presence or blend with interior schemes.



Axia® High Level Trolley (AX15T) with Sound Bar Mount (SBM1)

### High Level Solutions

- Includes PZX1 universal mount (VESA 200x200 to 600x400).
- Stylish plinth base with resilient non-marking feet.
- Trolley base features 7.5cm twin wheel castors for smooth movement.
- 4-way power socket neatly locates behind screen.
- Toughened glass or metal shelves available as required.
- Video conference accessories available, see page 30-31.



AX15P

AX15T

AX15BD

Part Code & Description	Cost £ (Exc. VAT)	Dimensions (H x W x Dmm)	Weight	Screen Size	VESA Fixing (Min / Max)	Weight Capacity	Colour
AX15P   High Level Plinth (Screen Centre: 1500mm)	575.60	1683 x 765 x 580	33.7kg	33 - 70"	200x200 / 600x400	60kg	■ □
AX15T   High Level Trolley (Screen Centre: 1600mm)	615.20	1754 x 887 x 656	31.8kg	33 - 70"	200x200 / 600x400	60kg	■ □
AX15BD   High Level Bolt Down (Screen Centre: 1500mm)	579.40	1683 x 765 x 300	21.6kg	33 - 70"	200x200 / 600x400	60kg	■ □

### Low Level Solutions

- Includes PZX1 universal mount (VESA 200x200 to 600x400).
- Stylish plinth base with resilient non-marking feet.
- Trolley base features 7.5cm twin wheel castors for smooth movement.
- 4-way power socket neatly locates behind screen.
- Toughened glass or metal shelves available as required.
- Video conference accessories available, see page 30-31.



AX12P

AX12T

AX10P

Part Code & Description	Cost £ (Exc. VAT)	Dimensions (H x W x Dmm)	Weight	Screen Size	VESA Fixing (Min / Max)	Weight Capacity	Colour
AX12P   Low Level Plinth (Screen Centre: 1200mm)	515.70	1290 x 765 x 580	31.8kg	33 - 70"	200x200 / 600x400	60kg	■ □
AX12T   Low Level Trolley (Screen Centre: 1200mm)	554.60	1400 x 886 x 656	29.7kg	33 - 70"	200x200 / 600x400	60kg	■ □
AX10P   Low Level Plinth (Screen Centre: 1000mm)	521.10	1135 x 765 x 450	27.4kg	33 - 57"	200x200 / 600x400	60kg	■ □
AX10T   Low Level Trolley (Screen Centre: 1000mm)	555.00	1248 x 886 x 556	31.1kg	33 - 57"	200x200 / 600x400	60kg	■ □

### Twin Screen Solutions

- Includes PZX1 universal mount (VESA 200x200 to 600x400) and toughened glass shelf.
- Internally strengthened units for twin screen use.
- 4-way power socket neatly locates behind screen.
- Video conference accessories available, see page 30-31.



AXC15T

AXC15BD

Please state screen make and model when ordering. Call for any advice or assistance as required.

Part Code & Description	Cost £ (Exc. VAT)	Dimensions (H x W x Dmm)	Weight	Screen Size	VESA Fixing (Min / Max)	Weight Cap.	Colour
AXC15P   Twin Screen Plinth (Screen Centre: 1500mm)	910.30	1660 x variable x 734	variable	33 - 57"	200x200 / 600x400	35kg*	■ □
AXC15T   Twin Screen Trolley (Screen Centre: 1600mm)	1080.50	1775 x variable x 734	variable	33 - 57"	200x200 / 600x400	35kg*	■ □
AXC15BD   Twin Screen Bolt Down (Screen Centre: 1500mm)	984.50	1615 x variable x 505	variable	33 - 57"	200x200 / 600x400	35kg*	■ □

\*max weight per screen

### Axia Accessories

Product Image	Part Code & Description	Cost £ (Exc. VAT)	Dimensions (H x W x Dmm)	Weight	Weight Capacity	Colour
	AXGS   500w x 400d Toughened Glass Shelf	78.80	70 x 500 x 480	4.1kg	20kg	■ □
	AXWS   780w x 390d Toughened Glass Shelf	89.20	70 x 780 x 440	6.2kg	20kg	■ □
	AXSS   500w x 400d Metal Shelf	69.50	70 x 500 x 444	4.9kg	20kg	■ □
	AXLC   Axia Locking Cabinet Internal Dimensions: 150h x 550w x 400d mm	188.60	170 x 563 x 483	17.8kg	30kg	■ □



## The Adaptable Stand System

From boardroom to show venue - the Avecta® range is a flexible and adaptable stand system with excellent cable management. Static or wheeled versions available, for single or twin screens.

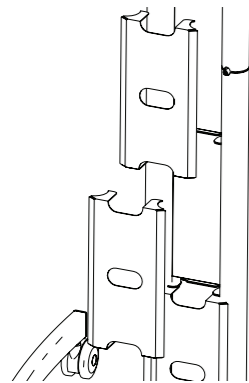

Avecta® High Level Stand (AVHP) with Video Conference Sound Bar Mount (VCSS1)

### Easy to Use Cable Management

Snap-in panel sections provides excellent cable management and is readily adaptable for height adjustment of stands and trolleys.

### Dedicated Microsoft Surface Hub 2S Unit

Custom designed trolleys for the 50" Microsoft Surface Hub 2S. Scan for other Hub mounts.



### High Level Solutions

- Includes PZX1 universal mount (VESA 200x200 to 600x400), AVP1 metal shelf and 4-way power socket.
- Height to centre of screen is adjustable from 1100 - 1500mm.
- AVHTSURH height to centre of screen is adjustable from 1250 - 1520mm.
- Trolley base features 7.5cm twin wheel castors for smooth movement.
- 4-way power socket neatly locates behind screen.
- Video conference accessories available, see page 30-31.



Part Code & Description	Cost £ (Exc. VAT)	Dimensions (H x W x Dmm)	Weight	Screen Size	VESA Fixing (Min / Max)	Weight Capacity	Colour
AVHP   Standard Plinth (Screen Centre: 1100-1500mm)	651.05	1533 x 760 x 580	44.2kg	33 - 70"	200x200 / 600x400	60kg	■ □
AVHT   Standard Trolley (Screen Centre: 1100-1500mm)	691.20	1630 x 890 x 605	42.3kg	33 - 70"	200x200 / 600x400	60kg	■ □
AVHTR1   Standard Trolley with RTM10 RotaMount (Screen Centre: 1100-1500mm)	769.30	1730 x 890 x 605	38.5kg	33 - 70"	200x200 / 600x400	60kg	■ □
AVHTSURH   MS Hub 2S Trolley (Screen Centre: 1250-1520mm)	769.30	1584 x 890 x 605	36.1kg	50"	350x350	60kg	■ □
AVHBD   Standard Bolt Down (Screen Centre: 1100-1400mm)	615.60	1520 x 765 x 481	21.5kg	33 - 70"	200x200 / 600x400	60kg	■ □
AVHW   Floor-to-Wall Stand (Fully Adjustable Screen Centre)	887.00	2514 x 765 x 470	37.4kg	33 - 70"	200x200 / 600x400	60kg	■ □

### Low Level Solutions

- Includes PZX1 universal mount (VESA 200x200 to 600x400), AVP1 metal shelf and 4-way power socket.
- Stylish plinth base with resilient non-marking feet.
- Trolley base features 7.5cm twin wheel castors for smooth movement.
- 4-way power socket neatly locates behind screen.



Part Code & Description	Cost £ (Exc. VAT)	Dimensions (H x W x Dmm)	Weight	Screen Size	VESA Fixing (Min / Max)	Weight Capacity	Colour
AVLP   Standard Plinth (Screen Centre: 600-950mm)	525.50	1034 x 760 x 580	39.3kg	33 - 70"	200x200 / 600x400	60kg	■ □
AVLT   Standard Trolley (Screen Centre: 600-950mm)	565.65	1127 x 877 x 604	37.4kg	33 - 70"	200x200 / 600x400	60kg	■ □

### Twin Screen Solutions

- Includes PZX1 universal mount (VESA 200x200 to 600x400), AVP1 metal shelf and 4-way power socket.
- Stylish plinth base with resilient non-marking feet.
- Trolley base features 7.5cm twin wheel castors for smooth movement.
- Video conference accessories available, see page 30-31.



Please state screen make and model when ordering. Call for any advice or assistance as required.

Part Code & Description	Cost £ (Exc. VAT)	Dimensions (H x W x Dmm)	Weight	Screen Size	VESA Fixing (Min / Max)	Weight Capacity	Colour
ACHP   Standard Plinth (Screen Centre: 1100-1500mm)	1077.10	1657 x variable x 607	variable	33 - 57"	200x200 / 600x400	35kg*	■ □
ACHT   Standard Trolley (Screen Centre: 1100-1500mm)	1057.30	1660 x variable x 607	variable	33 - 57"	200x200 / 600x400	35kg*	■ □

\*max weight per screen

### Avecta® Accessories

Product Image	Part Code & Description	Cost £ (Exc. VAT)	Dimensions (H x W x Dmm)	Weight	Weight Capacity	Colour
AVGS	AVGS   500w x 400d Toughened Glass Shelf	93.80	58 x 500 x 475	4.5kg	20kg	■ □
AVP1	AVP1   500w x 400d Metal Shelf	46.05	52 x 510 x 464	4.9kg	20kg	■ □
	AVP2   550w x 450d Metal Shelf	54.20	52 x 550 x 533	6.6kg	20kg	■ □
	AVP3   300w x 300d Metal Shelf	34.40	52 x 310 x 364	2.6kg	20kg	■ □
AVP4	AVP4   440w x 350d Fold-Down Metal Shelf	97.60	Shelf Up: 152 x 435 x 427 Shelf Down: 425 x 435 x 142	3.4kg	20kg	■ □
AVLC	AVLC   Avecta Locking Cabinet Internal Dimensions: 150h x 500w x 400d mm	177.38	194 x 592 x 542	16.0kg	20kg	■ □



## The Industry Standard for Exhibitions and Conferences

The Parabella® is a well proven stand that caters for screens up to 80" - ideal for exhibition and conference venues. Neat cable management and a 1.8m viewing height allows the screen to stand out amongst the crowd.

- Curved slim design.
- Neat, concealed cable management.
- Supplied with PZW1 (PA2) or PZX9 (PA9) mounts.
- Plus video conference accessories, see page 30-31.



Please state screen make and model when ordering. Call for any advice or assistance as required.

Part Code & Description	Cost £ (Exc. VAT)	Dimensions (H x W x Dmm)	Weight	Screen Size	VESA Fixing (Min / Max)	Weight Capacity	Colour
PA2   Standard Parabella® (Screen Centre: 1800mm)	577.60	1955 x 860 x 650	40.9kg	40 - 70"	200x200 / 600x400	80kg	■ □
PA9   Heavy Duty Parabella® (Screen Centre: 1800mm)	1043.90	1955 x 1210 x 700	61.7kg	71 - 80"	300x300 / 1000x600	80kg	■ □
PARAG2S   500w x 400d Toughened Glass Shelf	82.90	87 x 500 x 456	5.0kg	n/a	n/a	20kg	■ □
PARAB2   Large Parabella® Base (1210w x 700d mm)	370.00	13 x 1210 x 700	28.8kg	n/a	n/a	n/a	■ □
CTPA3   Parabella® Mount Converter (up to 80")	110.10	356 x 356 x 132	7.0kg	71 - 80"	n/a	80kg	■ □
PARAES4B   Parabella® 4-Way UK Power Socket (4m cable)	46.80	90 x 300 x 72	1.6kg	n/a	n/a	n/a	■ □

## Tevella™ Range - The Ideal Stands for Small Screens

The Tevella™ single column stands are ideal as digital information screens in office receptions, car showrooms, museums, art exhibits and more.

- Lightweight, easy to assemble solution.
- Cables concealable through column & base.
- Includes small screen mount.
- Tablet mount versions available.

### NEW! Tablet Mount Range

See all the possibilities for configuring tablet mount versions to exactly suit your needs in the items listed on page 33.



Part Code & Description	Cost £ (Exc. VAT)	Dimensions (H x W x D mm)	Weight	Screen Size	VESA Fixing (Min / Max)	Weight Capacity	Colour
TVV1   Tevella™ Upright Stand (Screen Centre: 1000mm)	160.80	1014 x 520 x 413	14.0kg	15 - 32"	75x75 / 200x100	15kg	■ □
TVL1   Tevella™ Lectern Stand (Screen Centre: 1000mm)	220.80	1040 x 500 x 500	13.0kg	15 - 32"	75x75 / 200x100	15kg	■ □
TVT1   Tevella™ Standard Trolley (Screen Centre: 1400mm)	234.45	1437 x 600 x 560	11.0kg	15 - 40"	75x75 / 200x100	15kg	■ □
TVB1   Tevella™ Bolt Down (Screen Centre: 1000mm)	204.40	1014 x 295 x 240	7.4kg	15 - 40"	75x75 / 200x100	15kg	■ □



## The Complete Teaching Assistant

The Nest-Star® is a complete teaching assistant on wheels that can be deployed quickly and neatly stowed when not in use.

This robust trolley supports your displays and securely houses your AV devices. The standard trolley comes with a plain mast. However, we understand that choice of equipment is important and will customise the rear of front of the mast section as required at an additional cost (please call for a quote). Handles are provided for ease of movement as standard.

- Quick and easy deployment.
- Custom cut-outs are available on the front of the mast.
- Secure storage for players / PCs.
- Custom colour options are available.
- PowaLift® version on page 17.
- Video conference accessories available, see pages 30-31.



Part Code & Description	Cost £ (Exc. VAT)	Dimensions (H x W x Dmm)	Weight	Screen Size	VESA Fixing (Min / Max)	Weight Capacity	Colour
NST1   Standard Plain Mast Trolley (Screen Centre: 1500mm)	1510.20	1550 x 1407 x 710	56.3kg	33 - 70"	200x200 / 600x400	80kg	■ □
NST2   HD Plain Mast Trolley (Screen Centre: 1500mm)	1585.70	1550 x 1407 x 710	62.9kg	71 - 90"	300x300 / 1000x600	150kg	■ □

## Large Screen Lecterns

### Fixed Height / Fixed Angled Version

A rigid and stable platform with fixed angle screen mount. The mast incorporates two compartments, both 344(w) x 95(d) - 1 x 280(h) & 1 x 398 (h), to house small devices together with cabling. Base unit has resilient, non-marking feet and clearance for cables routed beneath.



### Height & Tilt Adjustable Version

Operated by manual switch, screens can be commanded to rise or descend smoothly through 500mm, stopping safely when required. Screen angle can be manually moved through 90° and locked at any point. TL2HD comes with mount and full cable management.

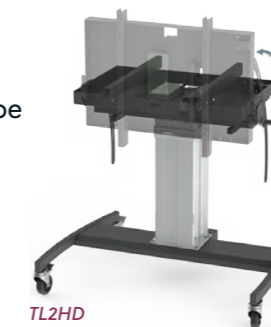

Please state screen make and model when ordering. Please note: TL2HD prices quoted are ex-works as this unit is despatched by dedicated courier or may be collected.

Part Code & Description	Cost £ (Exc. VAT)	Dimensions (H x W x Dmm)	Weight	Screen Size	VESA Fixing (Min / Max)	Weight Cap.	Col.
TL1   Fixed Height / Angled Version (Screen Centre: 930mm)	577.50	1068 x 740 x 579	41.7kg	33 - 70"	200x200 / 600x400	80kg	■
TL2HD   Adjustable Version (Screen Centre: 1000-1500mm)	POA	1000-1500 x 1085 x 750	67.7kg	71 - 110"	dedicated	120kg	■



## The Complete Corporate Communications Platform

With its clean lines and superior finish options, the Rhobus range of stands and trolleys answers all the needs of the corporate user.

Choose from the elegant single screen version through to multi-screen units to support the latest and best in corporate communications. A wide range of accessories are available to enhance the collaborative experience, including glass shelves and video conferencing mounts (pages 30-31).

For Powalift® versions, see page 17.

### Lockable AV Equipment Storage & Cable Management

Ample capacity provided within an accessible locking door in the central mast for cabling, codecs and more.

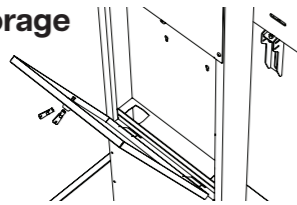

### Easily Swap-Over From Wheeled Base to Static

All Rhobus® trolleys allow users to easily swap from mobile trolley version to static base version at any time. Exc. RH200-HD & RH200-UHD.



Rhobus Standard Trolley (RH100) with Twin Sound Bar & Video Conference Mount (VCTS1)

### Standard Options

- Includes PZX1 universal mount (VESA 200x200 to 600x400).
- Easily swap from castors to static feet.
- Easy access to 440 x 470 x 80mm mast housing via lockable pull down door.
- All have a 1400mm high mast.
- Built in 4-way power socket included as standard.
- Single box solution.
- Video conference accessories available, see pages 30-31.



RH100

RH100-PZX5

RFWSH

Part Code & Description	Cost £ (Exc. VAT)	Dimensions (H x W x Dmm)	Weight	Screen Size	VESA Fixing (Min / Max)	Weight Capacity	Colour
RH100   Standard Trolley* (Screen Centre: 1480mm)	1265.20	1576 x 950 x 550	60.1kg	33 - 70"	200x200 / 600x400	80kg	■ □
RH100-PZX5   Trolley Inc. PZX5 (Screen Centre: 1480mm)	1265.20	1576 x 950 x 550	59.7kg	33 - 75"	200x200 / 800x600	80kg	■ □
RHBD100   Standard Bolt Down (Screen Centre: 1370mm)	1096.50	1470 x 650 x 310	45.5kg	33 - 70"	200x200 / 600x400	80kg	■ □
RFWSH   Standard Floor-to-Wall (Screen Centre: 1600mm)	1083.20	1710 x 765 x 207	35.1kg	33 - 57"	200x200 / 600x400	80kg	■ □
RHU   Standard Trolley Exc. Mount	1166.80	1576 x 950 x 550	54.8kg	n/a	n/a	80kg	■ □

\*FREE 500w x 400d toughened glass shelf (RHGS1) available whilst stock last (optional)

### Heavy Duty Options

- Includes PZX9 universal mount (VESA 300x300 to 1000x600).
- Easy access to 440 x 470 x 80mm mast housing via lockable pull down door.
- All have an 1800mm high mast.
- Built in 4-way power socket included as standard.
- Single box solution.
- Video conference accessories available, see below and pages 30-31.



RH100-HD

RHBD100-HD

RFWSH-HD

Part Code & Description	Cost £ (Exc. VAT)	Dimensions (H x W x Dmm)	Weight	Screen Size	VESA Fixing (Min / Max)	Weight Capacity	Colour
RH100-HD   HD Trolley (Screen Centre: 1700mm)	1780.60	1882 x 1200 x 660	79.4kg	71 - 110"	300x300 / 1000x600	150kg	■ □
RHBD100-HD   HD Bolt Down (Screen Centre: 1600mm)	1246.70	1775 x 1070 x 310	56.7kg	71 - 110"	300x300 / 1000x600	150kg	■ □
RFWSH-HD   HD Floor-to-Wall (Screen Centre: 1600mm)	1157.30	1710 x 1070 x 207	41.6kg	71 - 110"	300x300 / 1000x600	150kg	■ □

### Twin & Multi Screen Options

- RH200 includes 2x PZX1 universal mount (VESA 200x200 to 600x400) and 1400mm high mast.
- RH200-HD & RH200-HDP include universal mount arms and have an 1800mm high mast.
- Floor-to-Wall versions available.
- Built in 4-way power socket included.
- Video conference accessories available, see below and pages 30-31.



RH200

RH200-HD

Please note: RH200-UHD prices quoted are ex-works as this unit is despatched by dedicated courier or may be collected.

Part Code & Description	Cost £ (Exc. VAT)	Dimensions (H x W x Dmm)	Weight	Screen Size	VESA Fixing (Min / Max)	Weight Cap.	Col.
RH200   Twin Screen Trolley (Screen Centre: 1470mm)	1562.80	1577 x variable x 660	variable	33 - 70"	200x200 / 600x400	35kg*	■ □
RH200-HD   HD Twin Screen Trolley (Screen Centre: 1900mm)	2156.70	1940 x 2663 x 650	75.8kg	71 - 86"	600x400 / 1000x600	50kg*	■ □
RH200-HDP   HD Twin Screen Plinth (Screen Centre: 1800mm)	2156.70	1831 x 2663 x 730	109kg	71 - 86"	600x400 / 1000x600	50kg*	■ □
RH200-UHD   Ultra HD Twin Screen (Screen Centre: 1800mm)	5828.00	2008 x 3262 x 730	153.9kg	71 - 110"	variable	100kg*	■ □
RH400-HD   2x2 Trolley (Max. Screen Dims: 1420w x 680h mm)	2040.50	1974 x 1800 x 660	112.8kg	33 - 57"	200x200 / 600x400	35kg*	■ □

\*max weight per screen

### Rhobus Accessories

Product Image	Part Code & Description	Cost £ (Exc. VAT)	Dimensions (H x W x Dmm)	Weight	Weight Capacity	Colour
	RHGS1   500w x 400d Toughened Glass Shelf	78.80	360 x 500 x 398	5.1kg	20kg	■ □
	RHGS2   780w x 390d Toughened Glass Shelf	89.20	360 x 780 x 398	7.1kg	20kg	■ □
	SBM1 / SBM9   Sound Bar Mount* (PZX1 / PZX9)	188.00	variable	variable	10kg	■
	VCSS1 / VCSS9   Sound Bar and VC Mount* (PZX1 / PZX9)	255.60	variable	variable	10kg	■
	VCMP / VCMP9   Video Camera Mount* (PZX / PZX9)	87.35	variable	variable	10kg	■
	RHRACK   Internal Mast Racking for RH100 & RH100-HD Internal Dimensions: 432h x 352w x 75d mm	250.00	626 x 390 x 98	5.2kg	n/a	■ □

\*See page 30-31 for more information





## NEW! Rhobus® Lite

Slim-line version of the well-proven Rhobus® range. Capable of accepting a wide variety of screen sizes with lockable equipment and cable management within mast. Convenient power cable input with built-in IEC socket. Bolt down or wheeled base versions available.

**Easily Swap-Over From Wheeled Base to Static Base at any Time**



**Rapid Set-Up with Removable Equipment Rack**

Easy to pre-populate the internal rack with codecs or other AV devices before installation.

**Ideal for Video Conferencing & Meeting Rooms**

Compatible with our Video Conference Mounts (pages 30-31) and standard Rhobus accessories (page 15).



RHLBD100

RHL100

Part Code & Description	Cost £ (Exc. VAT)	Dimensions (H x W x Dmm)	Weight	Screen Size	VESA Fixing (Min / Max)	Weight Capacity	Colour
RHL100   Standard Trolley (Screen Centre: 1480mm)	958.12	1577 x 656 x 614	52.8kg	33 - 57"	200x200 / 600x400	80kg	■ ■
RHLBD100   Standard Bolt Down (Screen Centre: 1375mm)	873.77	1470 x 495 x 260	36.9kg	33 - 57"	200x200 / 600x400	80kg	■ ■

## Extra Heavy Duty Versions for Large Format Screens

Axia® Titan stands and trolleys are designed for large format or multi-screen applications, these trolleys incorporate extra heavy duty mast sections and increased base footprint to accommodate large screen sizes and heavier loads. Braked wheels fitted as standard.

Comes with universal screen mount (PZX9) as standard. Optional toughened glass or all metal shelves available.

Even larger 2m stands and trolleys are available upon request. Please call us to discuss your needs.

**Safety Note:** Safety always being the first priority, we recommend large or heavy screens being installed by qualified personnel. Always manoeuvre and position trolleys on flat and even surfaces.

**Please note:** prices quoted are ex-works as this unit is despatched by dedicated courier or may be collected.



Axia Titan 1500mm Trolley (AXT15T)

Part Code & Description	Cost £ (Exc. VAT)	Dimensions (H x W x Dmm)	Weight	Screen Size	VESA Fixing (Min / Max)	Weight Capacity	Colour
AXT15T   Standard Trolley (Screen Centre: 1600mm)	1145.50	1662 x 1217 x 734	52.9kg	71 - 110"	300x300 / 1000x600	150kg	■ ■
AXT15BD   Standard Bolt Down (Screen Centre: 1500mm)	1245.80	1512 x 515 x 395	40.6kg	71 - 110"	300x300 / 1000x600	150kg	■ ■
AXT15P   Standard Plinth (Screen Centre: 1500mm)	1051.50	1545 x 1217 x 734	49.8kg	71 - 110"	300x300 / 1000x600	150kg	■ ■

## Electronic Control & PowaLift® Technology Combined

Operated by wireless remote or manual switching, the PowaLift™ range enables screens to be raised or lowered smoothly through 700mm stopping safely at any point.

These units serve many important needs, particularly in the field of education, enabling young children or wheel chair users to interact with touch screens. Height control also makes it easy to move units from one location to another through doorways.

- Comes complete with universal screen mount, hand-held remote plus manual switching and 4-way power socket as standard.
- Well proven technology.
- Quality, long life components.
- Caters for screens from 33 - 110".
- Laptop platform arms available.
- Video conference accessories available, see page 30-31.

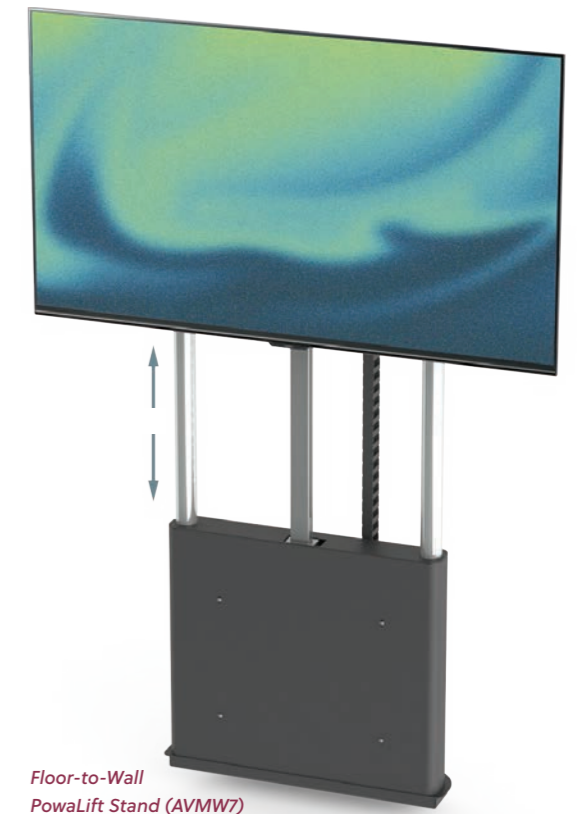

Floor-to-Wall PowaLift Stand (AVMW7)

**All These Versions Available:**



Part Code & Description	Cost £ (Exc. VAT)	Dimensions (H x W x Dmm)	Weight	Screen Size	VESA Fixings	Weight Capacity	Colour
AVMT71   PowaLift™ Trolley (Screen Centre: 896-1596mm)	1350.30	1804 x 1076 x 607	89.7kg	33 - 70"	200x200 / 600x400	100kg	■ ■
AVMW71   PowaLift™ Floor-to-Wall (Screen Centre: 844-1544mm)	1060.50	1662/1760 x 780 x 233	85.5kg	33 - 70"	200x200 / 600x400	100kg	■ ■
AVMW91   PowaLift™ Floor-to-Wall (Screen Centre: 844-1544mm)	1195.80	1662/1760 x 1070 x 273	81.8kg	71 - 110"	300x300 / 1000x600	150kg	■ ■
RHPL100-HD   Rhobus® Heavy Duty Trolley (Screen Centre: 1084-1784mm)	2170.80	1980 x 1200 x 659	100.3kg	71 - 110"	300x300 / 1000x600	150kg	■ ■
RHPLFW   Rhobus® Heavy Duty Floor-to-Wall (Screen Centre: 982-1682mm)	1909.35	1877 x 1070 x 400	78.2kg	71 - 110"	300x300 / 1000x600	150kg	■ ■
AXT15TPL   Axia® Titan Heavy Duty Trolley (Screen Centre: 1154-1854mm)	2080.40	2040 x 1224 x 732	73.5kg	71 - 110"	300x300 / 1000x600	200kg	■ ■
NST2PL   Nest-Star® Heavy Duty Trolley (Screen Centre: 950-1850mm)	2236.70	1998 x 1115 x 720	83.7kg	71 - 110"	300x300 / 1000x600	150kg	■ ■



### Convenient 'Package-Priced' Kits

These 'package-priced' kits offer ease and convenience for specifiers and installers, combining ceiling plate, chrome column & universal tilting mount for a typical installation. Wall fixable suspension kits also listed below.



### NEW! Multi-Screen Suspension Kits

Call us for product information and availability.

#### Ceiling Suspension Kits

- Single column solutions include PZW1 universal tilting mounts (VESA 200x200 to 600x400).
- For a smaller PZW3 universal mount, change the code prefix to 'KP3'.
- Twin column solutions either include a PZX9 universal mount (VESA 300x300 to 1000x600) or a PZX10 universal mount (VESA's up to 1500x600).
- For large back-to-back kits up to 110" - please call to discuss.



Part Code & Description	Cost £ (Exc. VAT)	Dimensions (H x W x Dmm)	Weight	Screen Size	VESA Fixing (Min / Max)	Weight Capacity	Colour
KP110CB   1m Single Screen Suspension Kit (PZW1)	215.00	1307 x 765 x 160	10.6kg	40 - 70"	200x200 / 600x400	60kg	■
KP120CB   2m Single Screen Suspension (PZW1)	247.50	2307 x 765 x 160	12.5kg	40 - 70"	200x200 / 600x400	60kg	■
KP130CB   3m Single Screen Suspension (PZW1)	280.00	3307 x 765 x 160	14.3kg	40 - 70"	200x200 / 600x400	60kg	■
KP920CB   2m Single Screen Suspension (PZX9)	459.50	2476 x 1070 x 293	32.2kg	71 - 110"	300x300 / 1000x600	120kg	■
KP930CB   3m Single Screen Suspension (PZX9)	524.50	3476 x 1070 x 293	35.9kg	71 - 110"	300x300 / 1000x600	120kg	■
KP1020CB   2m Single Screen Suspension (PZX10)	548.30	2476 x 1600 x 325	41.3kg	71 - 110"	400x600 / 1500x600	120kg	■
KP1030CB   3m Single Screen Suspension (PZX10)	613.30	3476 x 1600 x 325	44.9kg	71 - 110"	400x600 / 1500x600	120kg	■
KP110DB   1m Back-to-Back Screen Suspension Kit (PZW1x2)	365.00	1328 x 765 x 286	18.8kg	40 - 70"	200x200 / 600x400	45kg*	■
KP120DB   2m Back-to-Back Screen Suspension Kit (PZW1x2)	397.50	2328 x 765 x 286	20.6kg	40 - 70"	200x200 / 600x400	45kg*	■
KP130DB   3m Back-to-Back Screen Suspension Kit (PZW1x2)	430.00	3328 x 765 x 286	22.5kg	40 - 70"	200x200 / 600x400	45kg*	■

\*max weight per screen

#### Wall Arm Suspension Kits

- Single column solutions include PZW1 universal tilting mounts (VESA 200x200 to 600x400 versions).
- Small screen PZW3 universal mount versions available.
- For larger kits - please call to discuss.



Part Code & Description	Cost £ (Exc. VAT)	Dimensions (H x W x Dmm)	Weight	Screen Size	VESA Fixing (Min / Max)	Weight Capacity	Colour
KPWB1   Direct Coupled Wall Arm Kit (PZW1)	229.90	468 x 765 x 537	12.7kg	40 - 70"	200x200 / 600x400	60kg	■
KP105WB   0.5m Column Wall Arm Kit (PZW1)	247.60	903 x 765 x 537	14.1kg	40 - 70"	200x200 / 600x400	60kg	■
KP110WB   1m Column Wall Arm Kit (PZW1)	263.85	1403 x 765 x 537	15.0kg	40 - 70"	200x200 / 600x400	60kg	■

### Standing Out Made Simple!

Our popular alternative methods of floor-to-ceiling installation. Available as standard packages (up to a nominal 4m) or in component form using our standard components listed on pages 28-29. Floor fed services can be accommodated using ESF or AVF floor plates which provide cable management (see page 28). Ceiling heights greater than 4m can be accommodated using longer columns. Floor-to-Wall versions with 2m columns as standard, listed below.

### NEW! Twin Side-by-Side Screen Options

Call us for product information and various options available.

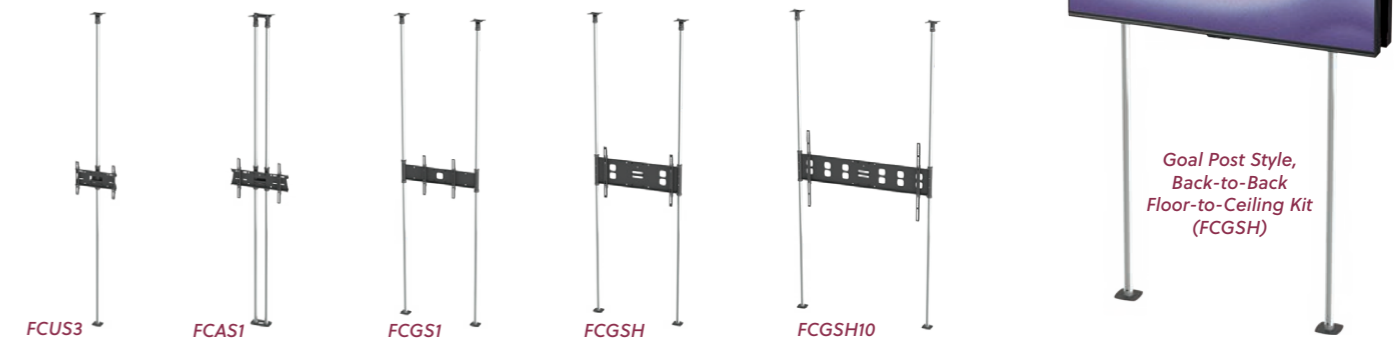

Part Code & Description	Cost £ (Exc. VAT)	Dimensions (H x W x Dmm)	Weight	Screen Size	VESA Fixing (Min / Max)	Weight Capacity	Col.
FCUS3   Single Column, Single Screen Kit (PZX3)	360.00	4094 x 540 x 176	16.0kg	40 - 57"	200x200 / 400x400	60kg	■
FCUD3   Single Column, Back-to-Back Screen Kit (PZX3x2)	468.30	4094 x 540 x 193	21.1kg	40 - 57"	200x200 / 400x400	35kg*	■
FCAS1   Twin Column, Single Screen Kit (PZX1)	614.35	4115 x 765 x 238	29.7kg	58 - 70"	200x200 / 600x400	60kg	■
FCAD1   Twin Column, Back-to-Back Screen Kit (PZX1x2)	723.30	4115 x 765 x 238	36.6kg	58 - 70"	200x200 / 600x400	35kg*	■
FCAVM   Twin Column Optional In-Fill Panels	396.00	n/a	13.2kg	n/a	n/a	n/a	■
FCGS1   Goal Post Columns, Single Screen Kits (FCS1)	537.80	4094 x 1160 x 160	28.7kg	58 - 70"	200x200 / 600x400	60kg	■
FCGD1   Goal Post Columns, Back-to-Back Screen Kit (FCS1)	636.20	4094 x 1160 x 160	34.3kg	58 - 70"	200x200 / 600x400	35kg*	■
FCGSH   Goal Post Columns, Single Screen Kit (FCS4)	667.50	4094 x 1295 x 160	35.1kg	71 - 110"	300x300 / 1000x600	120kg	■
FCGDH   Goal Post Columns, Back-to-Back Screen Kit (FCS4)	832.70	4094 x 1295 x 160	47.3kg	71 - 110"	300x300 / 1000x600	60kg*	■
FCGSH10   Goal Post Columns, Single Screen Kit (FCS10)	756.30	4094 x 1945 x 160	40.5kg	100 - 130"	1500x600 only	150kg	■

\*max weight per screen

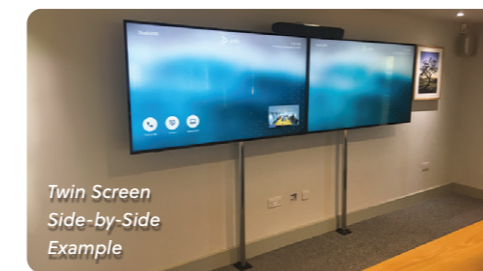

Twin Screen Side-by-Side Example



Part Code & Description	Cost £ (Exc. VAT)	Dimensions (H x W x Dmm)	Weight	Screen Size	VESA Fixing (Min / Max)	Weight Capacity	Col.
FWUS3   Single Column, Single Screen Kit (PZX3)	316.55	2060 x 540 x 200	11.3kg	40 - 57"	200x200 / 400x400	60kg	■
FWAS1   Twin Column, Single Screen Kit (PZX1)	400.65	2097 x 765 x 240	19.3kg	58 - 70"	200x200 / 600x400	60kg	■
FWAVM   Twin Column Optional In-Fill Panels	179.05	n/a	6.4kg	n/a	n/a	n/a	■
FWGS1   Goal Post Columns, Single Screen Kit (FCS1)	470.10	2007 x 1230 x 171	21.5kg	58 - 70"	200x200 / 600x400	60kg	■
FWGSH   Goal Post Columns, Single Screen Kit (FCS4)	599.80	2270 x 1365 x 171	28.0kg	71 - 110"	300x300 / 1000x600	120kg	■
FWGSH10   Goal Post Columns, Single Screen Kit (PZX10)	688.60	---- please enquire ----	---	100 - 130"	1500x600 only	150kg	■

\*max weight per screen



## Multi-Display Rail Systems

Our ScreenRail™ system allows integrators to mount screens in-line, in any number. Ideal for Digital Menus, Video Walls & Telepresence etc. Can be wall mounted or ceiling suspended.

ScreenRail™ systems comprise a choice of standard rail modules and a range of screen arms to cover all applications. Back-to-back versions are also available.

### Choose From Individual Components Listed Below or as Package Kits Opposite (page 21)

UNICOL's modular style allows you to mix and match components to create custom solutions to suit a wide range of requirements.

Installers are advised to call us with details of screen width and VESA fixing sizes to enable us to provide the ideal package solution.



MD2U140

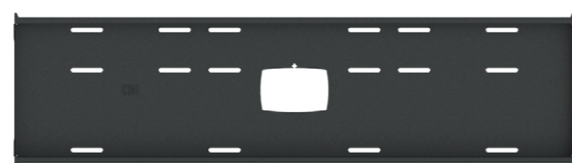

MD9U140

Product Image	Part Code & Description Specification	Cost £ (Exc. VAT)	Dimensions (H x W x Dmm)	Weight	Weight Capacity	Colour
	<b>PZF0   330mm High Standard Universal Mount Arms</b> (Pair of) Max VESA height of 200mm. Supplied with M4, M5, M6 & M8 fixings. Incorporates 5mm screen levelling. MD2U compatible.	41.50	332 x 41 x 40.5 (per arm)	1.2kg	60kg	■
	<b>PZF3   440mm High Standard Universal Mount Arms</b> (Pair of) Max VESA height of 400mm. Supplied with M4, M5, M6 & M8 fixings. Incorporates 5mm screen levelling. MD2U compatible.	41.50	440 x 41 x 40.5 (per arm)	1.4kg	60kg	■
	<b>PZF5   640mm High Standard Universal Mount Arms</b> (Pair of) Max VESA height of 600mm. Supplied with M4, M5, M6 & M8 fixings. Incorporates 5mm screen levelling. MD2U compatible.	41.50	640 x 41 x 40.5 (per arm)	1.9kg	60kg	■
	<b>PPZF5   840mm High Standard Universal Mount Arms</b> (Pair of) Max VESA height of 800mm. Supplied with M4, M5, M6 & M8 fixings. Incorporates 5mm screen levelling. MD2U compatible.	55.25	840 x 41 x 40.5 (per arm)	2.4kg	60kg	■
	<b>PPZF5   700mm High Heavy Duty Universal Mount Arms</b> (Pair of) Max VESA height of 600mm. Supplied with M4, M5, M6 & M8 fixings. Incorporates 5mm screen levelling. MD9U compatible.	61.50	700 x 41 x 45 (per arm)	2.8kg	150kg	■
	<b>VWA1   Landscape Tool-Less Fully Adjustable Arms</b> (Pair of) Max VESA height of 400mm. Features 15mm in-out adjustment and 15mm of fine levelling adjustment.	139.65	537 x 81 x 63 (per arm)	2.8kg	45kg	■
	<b>VWA2   Portrait Tool-Less Fully Adjustable Arms</b> (Pair of) Max VESA height of 600mm. Features 15mm in-out adjustment and 15mm of fine levelling adjustment.	139.65	740 x 81 x 63 (per arm)	3.6kg	45kg	■
	<b>MD2U35   350mm Standard Rail Module</b> Can be bolted together with other MD2U lengths to suit.*	69.80	350 x 235 x 33	1.6kg	45kg*	■
	<b>MD2U70   700mm Standard Rail Module</b> Can be bolted together with other MD2U lengths to suit.*	84.90	700 x 235 x 33	3.5kg	45kg*	■
	<b>MD2U140   1400mm Standard Rail Module</b> Can be bolted together with other MD2U lengths to suit.*	105.20	1400 x 235 x 33	6.3kg	45kg*	■
	<b>MD9U90   900mm Heavy Duty Rail Module</b> Can be bolted together with other MD9U lengths to suit.*	113.00	900 x 378 x 62	10.1kg	45kg*	■
	<b>MD9U140   1400mm Heavy Duty Rail Module</b> Can be bolted together with other MD9U lengths to suit.*	148.00	1400 x 378 x 62	14.7kg	45kg*	■
	<b>MD9UJ   Heavy Duty ScreenRail Joiner</b> Required for combining two MD9U rail modules.	34.00	346 x 335 x 35	3.0kg	45kg*	■
	<b>SR10   10° Fixed Tilt Optional Stand-Off Bracket</b> (Pair of)	36.20	186 x 85 x 85	1.1kg	n/a	■
	<b>SR20   20° Fixed Tilt Optional Stand-Off Bracket</b> (Pair of)	38.40	176 x 85 x 196	1.4kg	n/a	■

\*Other lengths of rail are available to order: 450mm, 800mm, 1000mm, 1200mm, 1700mm, 1800mm, 2100mm (MD2U) and 1000mm, 1600mm (MD9U).



## ScreenRail™ Menu Board Kits

- Pre-selected kits for 46", 50" or 55" screens. Please enquire for other sizes.
- Wall mounted or 1.5m column ceiling suspension options.
- All the parts necessary for fixing screens in-line.
- Includes VWA1 landscape tool-less fully adjustable arms.
- Quick and easy to install.

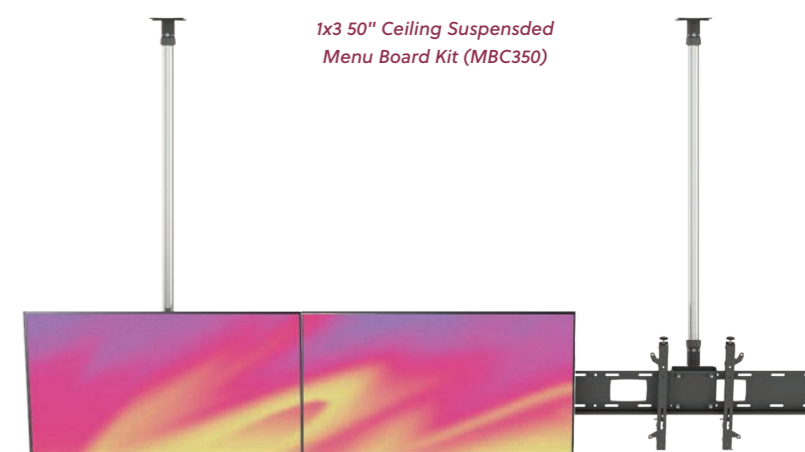

Please state screen make and model when ordering. Call for any advice or assistance as required.

Part Code & Description	Cost £ (Exc. VAT)	Dimensions (H x W x Dmm)	Weight	Screen Size	VESA Fixing (Min / Max)	Weight Capacity	Colour
<b>MBW346   3x1 46" Wall Mounted Menu Board Kit</b>	604.15	538 x 2800 x 69	21.1kg	46"	Max. Height: 400	35kg*	■
<b>MBW350   3x1 50" Wall Mounted Menu Board Kit</b>	651.75	538 x 3500 x 69	24.5kg	50"	Max. Height: 400	35kg*	■
<b>MBW355   3x1 55" Wall Mounted Menu Board Kit</b>	660.50	538 x 3600 x 69	25.1kg	55"	Max. Height: 400	35kg*	■
<b>MBW446   4x1 46" Wall Mounted Menu Board Kit</b>	870.00	538 x 4000 x 69	29.1kg	46"	Max. Height: 400	35kg*	■
<b>MBW450   4x1 50" Wall Mounted Menu Board Kit</b>	845.45	538 x 4210 x 69	31.0kg	50"	Max. Height: 400	35kg*	■
<b>MBW455   4x1 55" Wall Mounted Menu Board Kit</b>	916.60	538 x 4800 x 69	33.3kg	55"	Max. Height: 400	35kg*	■
<b>MBC346   3x1 46" Ceiling Suspended Menu Board Kit</b>	745.90	1798 x 2800 x 287	35.3kg	46"	Max. Height: 400	35kg*	■
<b>MBC350   3x1 50" Ceiling Suspended Menu Board Kit</b>	793.50	1798 x 3500 x 287	40.0kg	50"	Max. Height: 400	35kg*	■
<b>MBC355   3x1 55" Ceiling Suspended Menu Board Kit</b>	802.30	1798 x 3600 x 287	40.0kg	55"	Max. Height: 400	35kg*	■
<b>MBC446   4x1 46" Ceiling Suspended Menu Board Kit</b>	1011.75	1798 x 4000 x 287	48.5kg	46"	Max. Height: 400	35kg*	■
<b>MBC450   4x1 50" Ceiling Suspended Menu Board Kit</b>	996.20	1798 x 4210 x 287	50.5kg	50"	Max. Height: 400	35kg*	■
<b>MBC455   4x1 55" Ceiling Suspended Menu Board Kit</b>	1058.35	1798 x 4800 x 287	55.0kg	55"	Max. Height: 400	35kg*	■

\*max weight per screen

## ScreenRail™ Video Wall Kits

- Pre-selected kits for 46", 50" or 55" screens. Please enquire for other sizes.
- All the parts necessary for fixing screens in 2x2, 3x3 or 4x4 displays.
- Includes VWA1 landscape tool-less fully adjustable arms.
- Quick and easy to install.

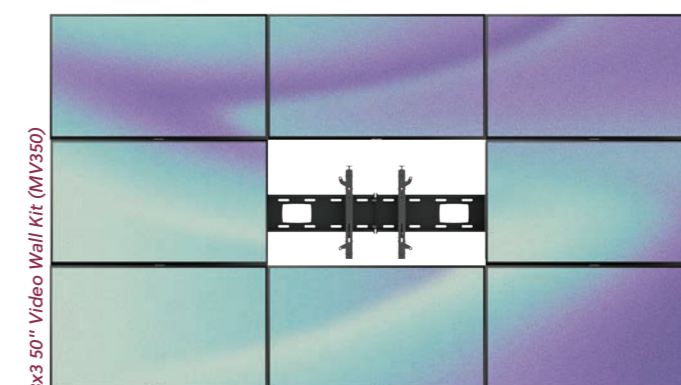

Please state screen make and model when ordering. Call for any advice or assistance as required.

Part Code & Description	Cost £ (Exc. VAT)	Dimensions (H x W x Dmm)	Weight	Screen Size	VESA Fixing (Min / Max)	Weight Capacity	Colour
<b>MV246   2x2 46" Video Wall Kit</b>	812.20	538 x 1800 x 69 (per row)	27.9kg	46"	Max. Height: 400	35kg*	■
<b>MV250   2x2 50" Video Wall Kit</b>	812.20	538 x 2100 x 69 (per row)	30.9kg	50"	Max. Height: 400	35kg*	■
<b>MV255   2x2 55" Video Wall Kit</b>	953.60	538 x 2100 x 69 (per row)	30.9kg	55"	Max. Height: 400	35kg*	■
<b>MV346   3x3 46" Video Wall Kit</b>	1812.45	538 x 2775 x 69 (per row)	63.4kg	46"	Max. Height: 400	35kg*	■
<b>MV350   3x3 50" Video Wall Kit</b>	2172.25	538 x 2398 x 69 (per row)	57.0kg	50"	Max. Height: 400	35kg*	■
<b>MV355   3x3 55" Video Wall Kit</b>	1981.65	538 x 3600 x 69 (per row)	75.4kg	55"	Max. Height: 400	35kg*	■
<b>MV446   4x4 46" Video Wall Kit</b>	3480.00	538 x 3998 x 69 (per row)	116.5kg	46"	Max. Height: 400	35kg*	■
<b>MV450   4x4 50" Video Wall Kit</b>	3417.80	538 x 4195 x 69 (per row)	124.0kg	50"	Max. Height: 400	35kg*	■
<b>MV455   4x4 55" Video Wall Kit</b>	3666.40	538 x 4795 x 69 (per row)	133.0kg	55"	Max. Height: 400	35kg*	■

\*max weight per screen



## Approved Mounts Specifically Designed for Each Make & Model

Xactmatch™ mounts take all the guesswork out of ordering and installing screen mounts. Whatever the make or model and whether stand, trolley, wall or ceiling fixed, our range covers all popular makes of screen and are available in landscape or portrait versions.

- Factory designed and tested for each screen model.
- Cable entry and cooling vent positions allowed for.
- Correct screen fixings included.

Please state screen make and model when ordering. Images are illustrative and final product may vary slightly from what is shown.



Part Code & Description	Cost £ (Exc. VAT)	Dimensions (H x W x Dmm)	Weight	Screen Size	VESA Fixing (Min / Max)	Weight Capacity	Colour
PLX1   Landscape Flat Dedicated Mount (up to 70")	129.20	variable	variable	33 - 70"	dedicated	80kg	■
PLX3   Landscape Flat Dedicated Mount (up to 110")	205.60	variable	variable	71 - 110"	dedicated	150kg	■
PPX1   Portrait Flat Dedicated Mount (up to 70")	129.20	variable	variable	33 - 70"	dedicated	80kg	■
PLW1   Landscape Tilting Dedicated Mount (up to 70")	148.40	variable	variable	33 - 70"	dedicated	80kg	■
PLW3   Landscape Tilting Dedicated Mount (up to 110")	230.50	variable	variable	71 - 110"	dedicated	150kg	■
PPW1   Portrait Tilting Dedicated Mount (up to 70")	148.40	variable	variable	33 - 70"	dedicated	80kg	■
PPW3   Portrait Tilting Dedicated Mount (up to 110")	230.50	variable	variable	71 - 110"	dedicated	150kg	■

## Smoothly Rotate Screens from Landscape to Portrait

Designed to be wall mounted or to fit with most UNICOL stands, trolleys and floor-to-ceiling systems. In-built safety stops allow precise indexing to both landscape and portrait positions. Supplied with screen mount. Use RotaMount™ in conjunction with our range of special Xactmatch™ mounts, stating make and model of screen when ordering. Larger display mounts also available - enquire to discuss.

**Safety Note:** Ensure safe cable management when using these units. Cables should be sheathed or otherwise protected and have sufficient freedom of movement.

Please state screen make and model when ordering. Images are illustrative and final product may vary slightly from what is shown.

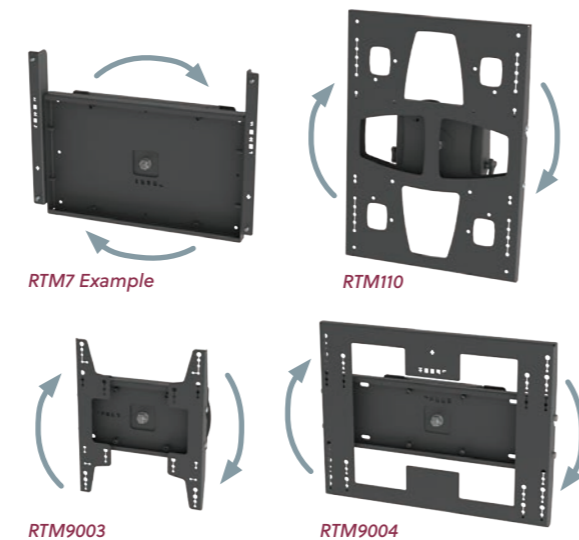

Part Code & Description	Cost £ (Exc. VAT)	Dimensions (H x W x Dmm)	Weight	Screen Size	VESA Fixing (Min / Max)	Weight Cap.	Col.
RTM1   Dedicated RotaMount™ inc. PLX Mount (up to 70")	248.20	variable	variable	33 - 70"	dedicated	75kg	■
RTM7   HD Dedicated RotaMount™ inc. PLX mount (up to 110")	428.30	variable	variable	71 - 110"	dedicated	75kg	■
RTM110   Universal Flat-to-Tilt VS1000 RotaMount™ (up to 70")	313.60	625 x 450 x 147	10.3kg	33 - 70"	200x200 / 600x400	75kg	■
RTM150   Universal Flat-to-Tilt Aucta RotaMount™ (up to 70")	313.60	625 x 450 x 147	10.3kg	33 - 70"	200x200 / 600x400	75kg	■
RTM9003   200x200 to 400x400 VESA Rotamount™ (up to 70")	248.20	454 x 366 x 81	6.7kg	33 - 70"	200x200 / 400x400	75kg	■
RTM9004   400x200 to 600x400 VESA Rotamount™ (up to 70")	248.20	490 x 635 x 86	11.7kg	33 - 70"	600x300 / 600x400	75kg	■



## Fully Adjustable, Industry Standard Universal Wall Mounts

The Pozimount® range is designed to work as a standalone wall mount or paired with any UNICOL stand, wall arm or ceiling suspension solution. Universal screen fixing kit supplied as standard. Stainless steel versions also available.



### Flat-to-Wall Versions

- Features double aperture and built-in screen levelling as standard.
- Covers VESA's up to 1500x1000!
- Portrait (PPZX) and landscape (PZX) versions available.

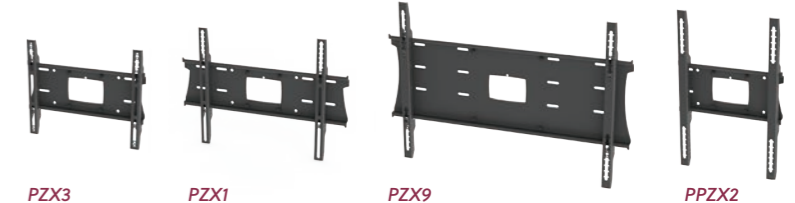

Part Code & Description	Cost £ (Exc. VAT)	Dimensions (H x W x Dmm)	Weight	Screen Size	VESA Fixing (Min / Max)	Weight Capacity	Colour
PZX0   100x100 to 400x200 VESA Universal Mount (up to 40")	98.40	332 x 465 x 45	3.4kg	30 - 40"	100x100 / 400x200	60kg	■
PZX3   200x200 to 400x400 VESA Universal Mount (up to 70")	98.40	440 x 540 x 45	4.1kg	33 - 70"	200x200 / 400x400	60kg	■
PZX1   200x200 to 600x400 VESA Universal Mount (up to 70")	98.40	540 x 765 x 45	5.5kg	33 - 70"	200x200 / 600x400	60kg	■
PZX5   200x200 to 800x600 VESA Universal Mount (up to 75")*	98.40	640 x 870 x 51	4.9kg	33 - 75"	200x200 / 800x600	60kg	■
PZX9   300x300 to 1000x600 VESA Universal Mount (up to 110")	165.20	700 x 1070 x 51	12.1kg	71 - 110"	300x300 / 1000x600	150kg	■
PZX10   400x600 to 1500x1000 VESA Universal Mount (up to 110")	254.00	1055 x 1600 x 52	21.1kg	71 - 110"	400x600 / 1500x1000	150kg	■
PPZX2   400x400 to 400x600 VESA Universal Mount (up to 70")	98.40	700 x 465 x 51	4.6kg	33 - 70"	400x400 / 400x600	60kg	■
PPZX9   300x300 to 600x1000 VESA Universal Mount (up to 110")	165.20	1055 x 765 x 51	9.9kg	71 - 110"	300x300 / 600x1000	150kg	■

\*up to 75" when installed as a wall mount or on RH100 ONLY. Otherwise compatible to 70".

### Tilting Versions

- Features double aperture and built-in screen levelling as standard.
- Patented finger tip tilt control makes viewing angle adjustment easy to set.
- Variable tilt from 0° to 11°.

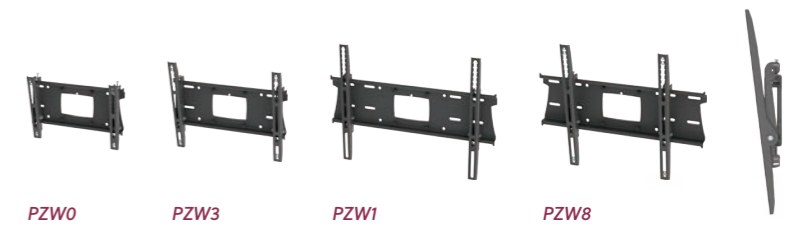

Part Code & Description	Cost £ (Exc. VAT)	Dimensions (H x W x Dmm)	Weight	Screen Size	VESA Fixing (Min / Max)	Weight Cap.	Colour
PZW0   200x100 to 400x200 VESA Universal Mount (up to 40")	118.40	327 x 465 x 64-115	4.0kg	30 - 40"	200x200 / 400x200	60kg	■
PZW3   200x200 to 400x400 VESA Universal Mount (up to 57")	118.40	435 x 540 x 64-115	4.7kg	33 - 70"	200x200 / 400x400	60kg	■
PZW1   200x200 to 600x400 VESA Universal Mount (up to 57")	118.40	535 x 765 x 64-115	6.2kg	33 - 70"	200x200 / 600x400	60kg	■
PZW8   200x200 to 600x400 VESA Universal Mount (up to 70")	150.80	535 x 700 x 64-115	6.2kg	33 - 75"	200x200 / 600x400	60kg	■

### Slim Profile Versions

- Please check that your screen has cable connections that allow for the use of a slim style wall mount.

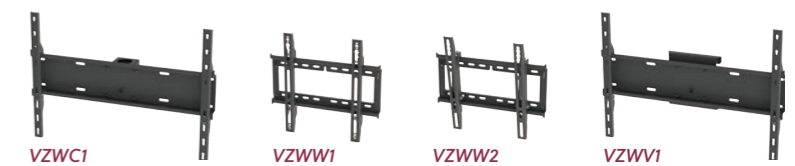

Part Code & Description	Cost £ (Exc. VAT)	Dimensions (H x W x Dmm)	Weight	Screen Size	VESA Fixing (Min / Max)	Weight Capacity	Colour
VZWC1   Ceiling Mount Version (0-11° Tilt)	93.70	450 x 650 x 109	3.6kg	40 - 57"	200x200 / 600x400	40kg	■
VZWW1   Wall Mount Version (Flat-to-Wall)	69.40	440 x 490 x 47	2.8kg	40 - 57"	200x200 / 400x400	40kg	■
VZWW2   Wall Mount Version (0-11° Tilt)	89.40	440 x 490 x 47-	3.4kg	40 - 57"	200x200 / 400x400	40kg	■
VZVV1   VS1000 Trolley Version (0-11° tilt)	96.80	450 x 650 x 67	3.6kg	40 - 57"	200x200 / 600x400	40kg	■



## Small Screen Mount Range

Our small screen mount range is designed for a variety of installation needs. Each mount is strongly made, easy to use and caters for a wide variety of small VESA sizes.

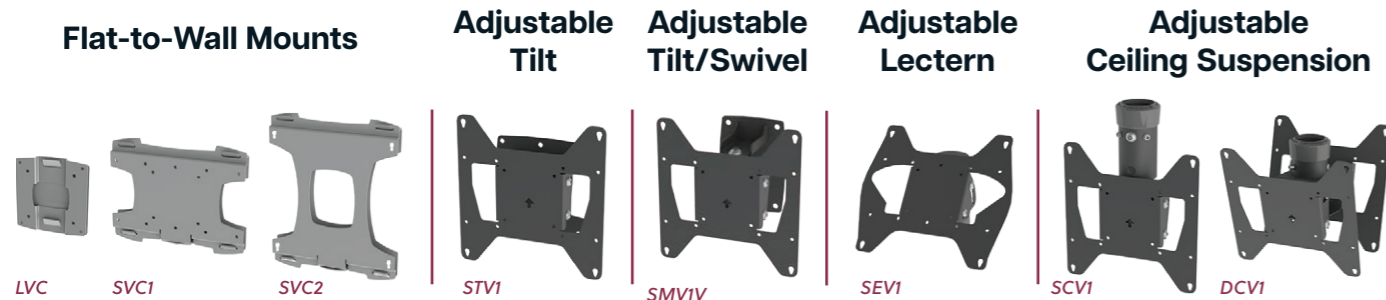

Part Code & Description	Cost £ (Exc. VAT)	Dimensions (H x W x Dmm)	Weight	Screen Size	VESA Fixing (Min / Max)	Weight Capacity	Colour
LVC   Slim-Line Wall Mount (up to 21")	17.80	123 x 116 x 11	0.3kg	15 - 21"	75x75 / 100x100	20kg	■
SVC1   Clip-On Slim-Line Wall Mount (up to 32")	45.10	175 x 220 x 22	0.9kg	15 - 32"	75x75 / 200x100	35kg	■
SVC2   Clip-On Slim-Line Wall Mount (up to 32")	55.10	275 x 220 x 23	1.2kg	15 - 32"	75x75 / 200x200	35kg	■
STV1   Tilting Wall Mount (up to 32")	59.30	224 x 220 x 48	1.0kg	15 - 32"	75x75 / 200x200	15kg	■
SMVIV   Swivel & Tilt Wall Mount (up to 32")	79.10	224 x 220 x 126-151	1.5kg	15 - 32"	75x75 / 200x200	15kg	■
SEV1   Lectern Style Single Column Mount (up to 32")	86.80	227 x 257 x 136	1.7kg	15 - 32"	75x75 / 200x200	15kg	■
SCV1   Swivel & Tilt Single Column Suspension (up to 32")	84.30	287 x 220 x 71-106	1.7kg	15 - 32"	75x75 / 200x200	15kg	■
DCV1   Swivel & Tilt Back-to-Back Suspension (up to 32")	136.50	224 x 220 x 159-232	2.3kg	15 - 32"	75x75 / 200x200	15kg	■

## NEW! Accession™ Service Mount

These pull-out serviceable mounts offer the ability to populate the perforated AV trays with a broad range of devices for a chosen installation, either on-site or remotely.

### Spacious & Efficient Servicing

Scissor action pull-out mount system provides an opening depth of 345mm for easy access to AV trays. Accommodate a wide variety of screen sizes.

### Integrated & Adaptable AV Trays

Twin AV trays can be moved laterally to any desired position to allow for mains and other cable inputs. \*Also accommodates Crestron Flex brackets.

### Video Conference Compatibility

Compatible with our range of sound bar, video bar and video conferencing mounts (see page 30).

Accession™ product range is subject to continuous development. Final products may therefore vary slightly from illustration shown.

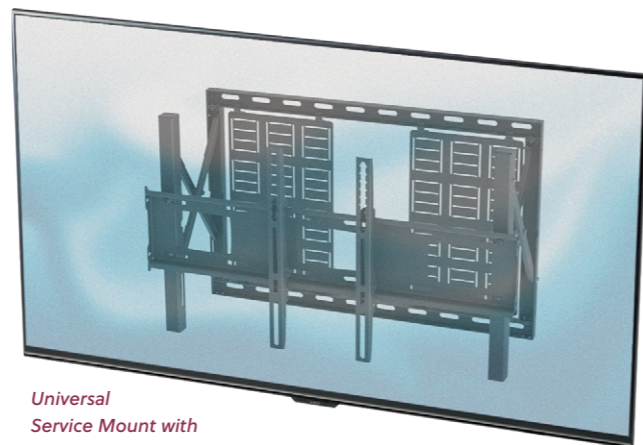

Universal Service Mount with 65" Screen (ASMW1)

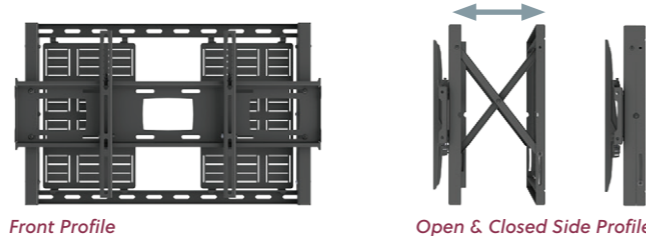

Front Profile

Open & Closed Side Profile

Part Code & Description	Cost £ (Exc. VAT)	Screen Size	Dimensions (H x W x Dmm)	Weight	VESA Fixing (Min / Max)	Weight Capacity	Colour
ASMW1   Universal Behind-Screen Service Mount	505.60	50-75"	-----	Please enquire for specifications	-----	-----	■

\*other versions also available - please call to discuss.

## Concealed Equipment Racks for Neat and Serviceable Device Storage

The VertiSlide™ serviceable cassette mount range incorporates wall fixed screen mounts with vertical or horizontal sliding, detachable slotted racks. Major benefits include;

- Enables AV equipment to be concealed securely out of sight behind the screen.
- Allows future single technician servicing of AV equipment without the need to remove heavy screens.
- In the event of AV equipment failure or upgrade speedy swap-out the rack can be achieved. Simply unlock, slide down or out the AV equipment tray.
- Choose between under-screen or side access units that best suits space availability.
- Video conferencing equipment can be mounted above or below screens (see page 31).

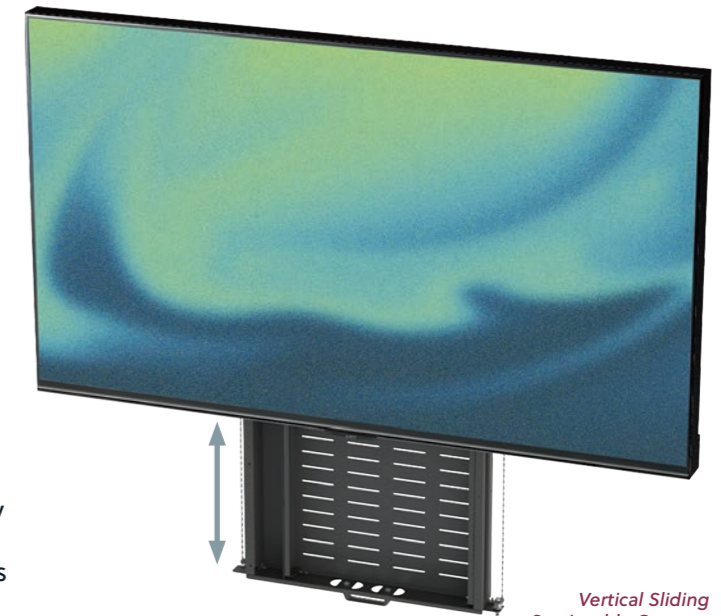

Vertical Sliding Serviceable Cassette Mount (VTS1) - Cassette Fully Opened

### VertiSlide™ Range as follows;

- Universal wall mounts up to 110".
- Ample storage space on racking:  
VTS1 rack: 495w x 588h mm  
VTS2 rack: 345w x 452h mm  
HTS1 rack: 599w x 495h mm  
HTS2 rack: 295w x 264h mm
- Video conference accessories available, see page 30-31.



VTS1 (Closed)

HTS1 (Closed)

Part Code & Description	Cost £ (Exc. VAT)	Dimensions (H x W x Dmm)	Weight	Screen Size	VESA Fixing (Min / Max)	Weight Capacity	Colour
VTS1   Vertical Sliding Serviceable Cassette (up to 110")	578.36	666-1184 x 784 x 80	25.2kg	71 - 110"	400x200 / 900x600	110kg	■
VTS2   Vertical Sliding Serviceable Cassette (up to 70")	384.24	520-886 x 634 x 80	18.1kg	46 - 70"	200x200 / 600x400	60kg	■
HTS1   Horizontal Sliding Serviceable Cassette (up to 110")	599.30	797 x 1567-2170 x 95	25.0kg	71 - 110"	200x200 / 1000x600	110kg	■
HTS2   Horizontal Sliding Serviceable Cassette (up to 70")	405.14	568 x 848-1248 x 95	15.2kg	46 - 70"	200x200 / 600x400	60kg	■

### Under-Desk Cassette Mounts

Our under-desk cassettes incorporate a hinged slotted removable rack for mounting small AV equipment. When installed, AV equipment remains securely hidden under desk. Whenever access or equipment upgrade is required, rack can be unlocked and hinged down for ready access. Unit incorporates neat easy close mechanism.



UDM (Closed)

UDM (Open)

\*Custom versions available in a wide range of sizes

Part Code & Description	Cost £ (Exc. VAT)	Dimensions (H x W x Dmm)	Internal Dims (H x W x Dmm)	Weight	Weight Capacity	Colour
UDM1   Universal Under-Desk Serviceable Cassette	256.60	70 x 590 x 400	65 x 585 x 395	3.8kg	10kg	■



## User Adjustable Swivel & Parallel Action Wall Mounts

The extra versatility of our Panarm™ range provides increased viewing flexibility and/or easy AV management when installed in alcoves or corners. These all steel, lasting quality and user adjustable joint tensioning arms extend to allow access to the rear of the screen. Fine level adjustment is featured as standard.

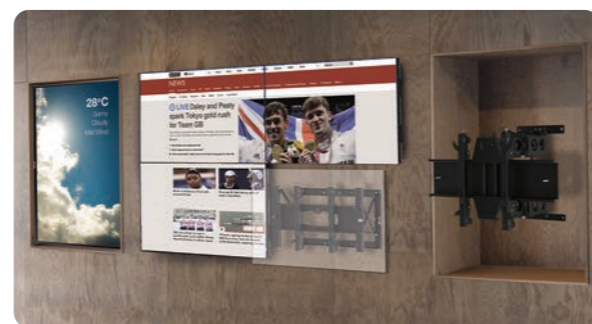

### Compact Small Screen Arms

- Compact folding size of just 77mm (SRV) or 84mm (SSV). Fully extend to 230mm (SRV) or 460mm (SSV)
- Fits small screen VESA sizes and offers up to 10° tilt.

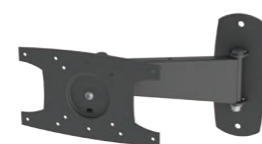

SRV (Folded)



SSV (Folded)

Part Code & Description	Cost £ (Exc. VAT)	Dimensions (H x W x Dmm)	Weight	Screen Size	VESA Fixing (Min / Max)	Weight Capacity	Colour
SRV   Compact Single Arm Wall Mount	87.10	190 x 220-335 x 77-230	2.0kg	15 - 32"	75x75 / 200x100	20kg	■
SSV   Compact Dual Arm Wall Mount	125.30	190 x 220-322 x 84-460	2.8kg	15 - 32"	75x75 / 200x100	20kg	■

### Heavy Duty Single & Dual Arms

- Units fold 115mm (PLS) / 155mm (PLA) to wall and reach 430mm (PLS) / 730mm (PLA).
- Fitted with universal screen mount.
- Offers full swivel and tilt.
- Use PZX3 for 32" or portrait mounting.



PLS1X1 (Extended)



PLA1X1 (Extended)

Part Code & Description	Cost £ (Exc. VAT)	Dimensions (H x W x Dmm)	Weight	Screen Size	VESA Fixing (Min / Max)	Weight Capacity	Colour
PLS1X1   Heavy Duty Single Arm Wall Mount (PZX1)	206.80	540 x 765 x 123-432	9.9kg	33 - 57"	200x200 / 600x400	35kg	■
PLS1X3   Heavy Duty Single Arm Wall Mount (PZX3)	206.80	440 x 540-654 x 123-432	8.4kg	33 - 57"	200x200 / 400x400	35kg	■
PLA1X1   Heavy Duty Dual Arm Wall Mount (PZX1)	242.10	540 x 765 x 155-728	12.5kg	33 - 57"	200x200 / 600x400	30kg	■
PLA1X3   Heavy Duty Dual Arm Wall Mount (PZX3)	242.10	440 x 540-585 x 155-728	11.0kg	33 - 57"	200x200 / 400x400	30kg	■

### Heavy Duty Parallel Action Dual Arms

- PLA2X1 features a PZX1, folds to 155mm and fully extends to 580mm.
- PLA2X9 features a PZX9, folds to 194mm and fully extends to 620mm.
- PLA4 has a build in mount, folds to 120mm and fully extends to 535mm
- PLA4 also features adjustable stops to prevent screens being pushed in.



PLA2X1 (Extended)



PLA4 (Extended)

Part Code & Description	Cost £ (Exc. VAT)	Dimensions (H x W x Dmm)	Weight	Screen Size	VESA Fixing (Min / Max)	Weight Cap.	Colour
PLA2X1   Heavy Duty Parallel Action Dual Arm (up to 70")	288.10	540 x 765 x 153-579	18.0kg	58 - 70"	200x200 / 600x400	60kg	■
PLA2X9   Heavy Duty Parallel Action Dual Arm (up to 90")	400.70	700 x 1070 x 194-620	27.4kg	71 - 90"	300x300 / 1000x600	60kg	■
PLA4   Heavy Duty Parallel Action Dual Arm (up to 110")	985.25	535 x 870 x 118-535	23.4kg	71 - 110"	400x400 / 900x600	130kg	■

## Wall Suspension Arms for Screens, Projectors, Guardboxes & More

These standard wall arm units are designed for use with our signature chrome columns, screen mounts, projector mounts and Guardboxes. There are two versions available;

- Peg ended allows direct connection of mount (using PS1 suspension adapter).
- Socket ended allows for column suspension. They can be fitted with any UNICOL screen or projector mount listed in this catalogue.



WB0

WB02

Other arm lengths (mm) are available, please enquire for more details. See pages 22 & 23 for screen mounts and page 28 for PS1 adapter.

Part Code & Description	Cost £ (Exc. VAT)	Dimensions (H x W x Dmm)	Arm Length	Weight	Weight Capacity	Colour
WB0   Small Wall Arm with Peg (356mm Arm Length)	58.20	263 x 117 x 390	356mm	2.8kg	25kg	■ □
WB02   Small Wall Arm with Socket (356mm Arm Length)	62.10	263 x 117 x 390	356mm	3.4kg	25kg	■ □
WB1   Large Wall Arm with Peg (461mm Arm Length)	76.10	391 x 172 x 510	461mm	5.0kg	55kg	■ □
WB2   Large Wall Arm with Socket (461mm Arm Length)	77.55	391 x 172 x 510	461mm	5.5kg	55kg	■ □

## Behind-Screen PC Housings

We manufacture screen mounts incorporating housings for small form factor PCs. These units greatly aid simple installation. Ample storage is provided by PC housing up to 320w x 100d x 330h mm, catering for a wide range of form factor and larger PC units.

Units listed below incorporate our Pozimount universal mounts in tilting and non-tilting versions.

### Custom Behind-Screen PC Housing Solutions

Our in-house design and manufacturing facilities are constantly developing solutions for a wide range of requirements. Call us to discuss your next project.

















Universal PC Housing with PZX1 (PCZX1)

Please state screen make and model and PC being housed when ordering.

Part Code & Description	Cost £ (Exc. VAT)	Dimensions (H x W x Dmm)	Weight	Screen Size	VESA Fixing (Min / Max)	Weight Capacity	Colour
PCZX1   Universal PC Housing with PZX1 Storage Dimensions: 330h x 320w x 100d mm	233.80	540 x 765 x 174	9.7kg	33 - 70"	200x200 / 600x400	60kg	■
PCZX3   Universal PC Housing with PZX3 Storage Dimensions: 330h x 320w x 100d mm	233.80	440 x 540 x 174	8.2kg	33 - 70"	200x200 / 400x400	60kg	■
PCZW1   Universal Flat-to-Tilt PC Housing with PZW1 Storage Dimensions: 330h x 320w x 100d mm	253.80	540 x 765 x 180	10.3kg	33 - 70"	200x200 / 600x400	60kg	■
PCZW3   Universal Flat-to-Tilt PC Housing with PZW3 Storage Dimensions: 330h x 320w x 100d mm	253.80	440 x 540 x 180	8.9kg	33 - 70"	200x200 / 400x400	60kg	■



 <p><b>Standard Ceiling Plate</b> Use with any column length for suspending projectors and single screens up to 57". Has cable entry. Plate holes: 120x120mm Max Weight Capacity: 60kg <b>CP1   £28.70 exc. VAT</b></p>	 <p><b>Large Ceiling Plate</b> For long column or heavy installations typically up to 70" or twin 57" screens. Has cable entry. Plate holes: 240x240mm Max Weight Capacity: 120kg <b>CP2   £42.90 exc. VAT</b></p>																		
 <p><b>Gantry Ceiling Plate</b> Primarily for spider gantry units. The internal safety mechanism allows limited movement &amp; protects fixings. Plate holes: 300x300 &amp; 500x500mm Max Weight Capacity: 270kg <b>CP5   £108.40 exc. VAT</b></p>	 <p><b>Anti-Vibration Ceiling Plate</b> Internal damping system provides floating action to reduce vibration from above. Plate holes: 120x185mm Max Weight Capacity: 60kg <b>CPAV1   £155.56 exc. VAT</b></p>																		
 <p><b>Tube Clamp</b> For suspending screens from lighting gantries, show stands or other structures. Screens up to 57". Tube Diameter: up to 50mm Max Weight Capacity: 45kg <b>TM05   £34.85 exc. VAT</b></p>	 <p><b>Truss Clamp</b> For suspending screens and projectors from standard truss. Truss Diameter: 40 - 55mm Max Weight Capacity: 120kg <b>CT1 (up to 57") £47.40 exc. VAT</b> <b>CT2 (with safety hook) £48.60 exc. VAT</b></p>																		
 <p><b>Internal Column Coupler</b> Concealed within the column, this coupler joins columns together via 'through-bolt' holes. For ceiling suspension use only. Max Weight Capacity: 120kg <b>CC   £19.45 exc. VAT</b></p>	 <p><b>Trim Disc</b> TD1 (5cm diameter) £8.65 exc. VAT</p>  <p><b>Retro-Fit Trim Disc</b> TDRF (fits post-install) £14.75 exc. VAT</p>  <p><b>Blanking Disc</b> TDB1 (cover 5cm dia. holes) £8.65 exc. VAT</p>																		
 <p><b>Single Column Suspension Adapter</b> Mount adapter for Pozimount and Xactmatch mounts when used for ceiling suspension. 360° swivel. Max Weight Capacity: 90kg <b>PS1   £64.30 exc. VAT</b></p>	 <p><b>Back-to-Back Single Column Suspension Adapter</b> Mount adapter for Pozimount and Xactmatch mounts. 360° swivel. Has cable entry. Typically suits up to 70". Max Weight Capacity: 90kg <b>PS5   £112.60 exc. VAT</b></p>																		
 <p><b>Single Column Adapters</b> Use in conjunction with Pozimount and Xactmatch mounts. Can also be used for fixing columns to walls. Max Weight Capacity: 90kg <b>PS3U1 (up to 70") £69.30 exc. VAT</b> For back-to-back use PS6UT1</p>	 <p><b>Twin Column Adapters</b> Use in conjunction with Pozimount and Xactmatch mounts. Can also be used for fixing twin columns to walls. Max Weight Capacity: 120kg <b>PS3V1 (33 - 70") £72.95 exc. VAT</b> <b>PS8 (back-to-back) £85.00 exc. VAT</b></p>																		
 <p><b>Chrome Column Lengths</b></p> <table border="1"> <tr><td>500</td><td>(500mm)</td><td>£16.25 exc. VAT</td></tr> <tr><td>1000</td><td>(1000mm)</td><td>£32.50 exc. VAT</td></tr> <tr><td>1500</td><td>(1500mm)</td><td>£48.75 exc. VAT</td></tr> <tr><td>2000</td><td>(2000mm)</td><td>£65.00 exc. VAT</td></tr> <tr><td>2500</td><td>(2500mm)</td><td>£81.25 exc. VAT</td></tr> <tr><td>3000</td><td>(3000mm)</td><td>£97.50 exc. VAT</td></tr> </table> <p>Add 'C' for ceiling suspension i.e 500C. Stainless steel available.</p>	500	(500mm)	£16.25 exc. VAT	1000	(1000mm)	£32.50 exc. VAT	1500	(1500mm)	£48.75 exc. VAT	2000	(2000mm)	£65.00 exc. VAT	2500	(2500mm)	£81.25 exc. VAT	3000	(3000mm)	£97.50 exc. VAT	 <p><b>Compact Bolt Down Bases</b> Minimal footprint for fixed screen stands. M10 floor bolts (not supplied) fully recess into the base. <b>ESF (single 290 x 240mm) £85.60 exc. VAT</b> <b>VSF (twin 400 x 300mm) £93.20 exc. VAT</b> <b>AVF (twin 150mm centres) £93.20 exc. VAT</b></p>
500	(500mm)	£16.25 exc. VAT																	
1000	(1000mm)	£32.50 exc. VAT																	
1500	(1500mm)	£48.75 exc. VAT																	
2000	(2000mm)	£65.00 exc. VAT																	
2500	(2500mm)	£81.25 exc. VAT																	
3000	(3000mm)	£97.50 exc. VAT																	

 <p><b>Stub Column Ceiling Plates</b> Allows direct connection of UNICOL PSU projector mounts etc. Max Weight Cap: 60kg (CP3) 120kg (CP4) <b>CP3 (120 x 120mm holes) £27.40 exc. VAT</b> <b>CP4 (240 x 240mm holes) £41.60 exc. VAT</b></p>	 <p><b>Tilting Ceiling Plate</b> For sloping or 'out-of-level' installations. Typically suits projectors and single screens up to 57". Plate holes: 120x120mm Max Weight Capacity: 60kg <b>CP6   £49.00 exc. VAT</b></p>
 <p><b>Twin Column Ceiling Plates</b> Typically suspends screens over 50". 110mm between sockets, enquire for 150mm centres. CP9 has 360° swivel. Max Weight Capacity: 200kg <b>CP8 (220 x 180mm holes) £65.70 exc. VAT</b> <b>CP9 (240 x 240mm holes) £122.30 exc. VAT</b></p>	 <p><b>Girder Clamps</b> For 75 - 250mm &amp; 75 - 350mm wide girders. Adjust from level to extreme angles of tilt. Wider versions available Max Weight Capacity: 120kg <b>GC25 (250mm span) £78.45 exc. VAT</b> <b>GC35 (350mm span) £82.55 exc. VAT</b></p>
 <p><b>Pipe Clamp</b> Available in a wide range of sizes up to 400mm. Please state pipe diameter when ordering. Pipe Diameter: typically 75 - 400mm Max Weight Capacity: 120kg <b>TM530   £68.20 exc. VAT</b></p>	 <p><b>Pillar Clamps</b> Please state circular pillar diameter when ordering. Up to 700mm. Max Weight Capacity: 120kg <b>VCC1 (single arm) £330.20 exc. VAT</b> <b>VCC2 (double arm) £360.50 exc. VAT</b> <b>VCC3 (triple arm) £390.80 exc. VAT</b></p>
 <p><b>Safety Locking Ring</b> Necessary at the lower end of any ceiling suspension installation using column mounted components, where safety 'through-bolts' are absent. Max Weight Capacity: 120kg <b>LR   6.70 exc. VAT</b></p>	 <p><b>Column Tilting Adapters</b> Use with Pozimount and Xactmatch mounts. Variable tilt to 15°. Has cable entry. Back-to-back available. Max Weight Capacity: 60 &amp; 120kg <b>PS7 (single column 60kg) £83.50 exc. VAT</b> <b>PS9 (twin column 120kg) £98.60 exc. VAT</b></p>
 <p><b>Twin Column Suspension Adapters</b> Adapter for PZW, PLX &amp; PLW mounts only (page 23). Has cable entry. Max Weight Capacity: 120kg <b>PS12 (up to 70") £74.30 exc. VAT</b> <b>PS123030 (up to 110") £96.50 exc. VAT</b></p>	 <p><b>Back-to-Back Twin Column Suspension Adapters</b> For heavy installs or where screens are subject to stress or wind loads. Max Weight Capacity: 120kg <b>PS4 (up to 70") £125.60 exc. VAT</b> <b>PS43030 (up to 110") £181.40 exc. VAT</b></p>
 <p><b>Floor-to-Ceiling Column Coupler</b> For mounting screens on two part columns. Use with Pozimount and Xactmatch mounts. Max Weight Capacity: 90kg <b>PS6U1 (33 - 70") £98.90 exc. VAT</b> <b>PS6UT1 (back-to-back) £110.60 exc. VAT</b></p>	 <p><b>Twin Column Floor-to-Ceiling Coupler</b> For mounting screens on two part columns. Column Centres: 110mm Max Weight Capacity: 120kg <b>PS6V1 (33 - 70") £108.90 exc. VAT</b></p>
 <p><b>Floor-to-Ceiling Base Plates</b> Available in single or twin column versions. Columns locate over bushes to give neat appearance. Has fixing holes through bushes. <b>FP1 (use with CP1) £26.50 exc. VAT</b> <b>FP8 (use with CP8) £58.70 exc. VAT</b></p>	 <p><b>Custom Made Components</b> We offer a service in making all kinds of special or non-standard components and accessories. Call +44 (0)1865 767676 to enquire when planning your next project!</p>



## Easy to Install, Dedicated Mounts for Video Conferencing

We design and manufacture sound bar and video conference mounts for many makes and models. These units allow video conference devices to be fixed to our stand & trolley ranges and ceiling suspension systems.

### Interchangeable Adapter Plates

Need to change the video conference device on an installation? Simply order a replacement adapter plate (WBSB or VCSB, see below) and fix your new device straight to your existing sound/video bar mount.



Sound Bar Mount for Universal Mounts (SBM1)

### Sound/Video Bar Mounts

- SBM hook onto our universal mount range.
- SBT has 150x150mm centres for twin screen mounting.
- SBC fixes to any UNICOL column length.
- Can be mounted above or below the screen.



Please state device make and model when ordering. Images are illustrative and final product may vary slightly from what is shown.

Part Code & Description	Cost £ (Exc. VAT)	Compatible with	Weight Cap.	Col.
SBM1   Sound Bar Mount for Universal Mounts	188.00	PZX1, PZX3, PZW1, PZW3, FCS1, KP1, KP3, MD2U	10kg	■
SBM9   Sound Bar Mount for Heavy Duty Universal Mounts	188.00	PZX9, FCS4, TCAVT, MD9U	10kg	■
SBT1   Sound Bar Mount for Twin Screen Stands/Trolleys	188.00	ACHP, ACHT, AXC15P, AXC15T, RH200, RH200-UHD	10kg	■
SBC   Sound Bar Mount for Ceiling Suspension	145.00	500C, 1000C, 1500C, 2000C, 3000C etc	10kg	■
SBT   Single Column Sound Bar Mount Adapter (add WBSB Adapter Plate)	73.70	500, 1000, 1500 etc & 500C, 1000C, 1500C etc	10kg	■

### Dual Sound Bar/Video Camera Mounts

- Fits an AV device above and below the screen by hooking onto our universal mount range.
- Select to mount either two sound/video bars, two video conference cameras or one of each!
- Select your DBSM mount and then add the relevant adapter plates to fit your choice of AV device.



Please state device make and model when ordering. Images are illustrative and final product may vary slightly from what is shown.

Part Code & Description	Cost £ (Exc. VAT)	Compatible with	Weight Cap.	Colour
DSBM1   Dual Sound Bar/Video Camera Mount for Universal Mounts	133.30	PZX1, PZW1, FCS1, KP1, MD2U	10kg	■
DSBM9   Dual Sound Bar/Video Camera Mount for HD Universal Mounts	133.30	PZX9, FCS4, TCAVT, MD9U	10kg	■
WBSB   Sound/Video Bar Adapter Plate	71.30	SBM / SBT / VCSS / VCTS	10kg	■
VCSB   Video Conference Camera Adapter Plate	71.30	SBM / SBT / VCSS / VCTS	10kg	■

### Video Conference Sound/Video Bar Mounts

- Designed to hook over our universal mount range.
- VCSS accommodate 1 speaker and a camera.
- VCTS accommodate 2 speakers and a camera.
- VCTST has 150x150mm centres for twin screen installs.
- Can be mounted above or below the screen.



Please state device make and model when ordering. Images are illustrative and final product may vary slightly from what is shown.

Part Code & Description	Cost £ (Exc. VAT)	Compatible with	Weight Cap.	Colour
VCSS1   Sound Bar & Video Camera Mount for Universal Mounts	225.60	PZX1, PZX3, PZW1, PZW3, FCS1, KP1, KP3, MD2U	10kg	■
VCSS9   Sound Bar & Video Camera Mount for HD Universal Mounts	225.60	PZX9, FCS4, TCAVT, MD9U	10kg	■
VCTS1   Twin Sound Bar & Video Camera Mount for Universal Mounts	275.90	PZX1, PZX3, PZW1, PZW3, FCS1, KP1, KP3, MD2U	10kg	■
VCTS9   Twin Sound Bar & Video Camera Mount for HD Universal Mounts	275.90	PZX9, FCS4, TCAVT, MD9U	10kg	■
VCTST   Twin Sound Bar & Video Camera Mount for Twin Screen	275.90	ACHP, ACHT, AXC15P, AXC15T, RH200, RH200-UHD	10kg	■

### Video Conference Camera Mounts

- VCM1 & VCMP slot/hook on to our universal mounts.
- VCMT has 150x150mm centres for large screen installs.
- MCM fixes to any UNICOL column length (page 28).
- Can be mounted above or below the screen.
- 360w x 260d mm universal platform supplied as standard with custom sizes available upon request.



Please state device make and model when ordering. Images are illustrative and final product may vary slightly from what is shown.

Part Code & Description	Cost £ (Exc. VAT)	Compatible with	Weight Cap.	Colour
VCM1   Standard Video Conference Camera Mount	87.90	PLX1, PLW1, PZX0, PZX1, PZX3, PZW0, PZW1, PZW3	10kg	■
VCMT   Heavy Duty Standard Video Conference Camera Mount	87.90	PZX9, PLX3, PLW3	10kg	■
VCMP1   VC Camera Mount for Universal Mounts	87.35	PZX1, PZX3, PZW1, PZW3, FCS1, KP1, KP3, MD2U	10kg	■
VCMP9   VC Camera Mount for Heavy Duty Universal Mounts	87.35	PZX9, FCS4, TCAVT, MD9U	10kg	■
VCMV1   VC Camera Mount for VertiSlide Serviceable Cassette Mounts	88.20	VTS1 & VTS2 only.	10kg	■
MCM   VC Camera Mount for Ceiling Suspension	95.60	500C, 1000C, 1500C, 2000C, 3000C etc	10kg	■

## NEW! Speaker Mounts

Take all the guesswork out of ordering and installing speakers.

We manufacture a wide range of custom speaker mounts for wall, trolley or ceiling suspension applications. Versions include side by side or above screen, ceiling suspended or wall mounted.

Please state device make and model when ordering. Images are illustrative and final product may vary slightly from what is shown.



Example mount for placing a Yamaha VXL1B-8 either side of a screen. Attaches to UNICOL's PZX universal mounts.

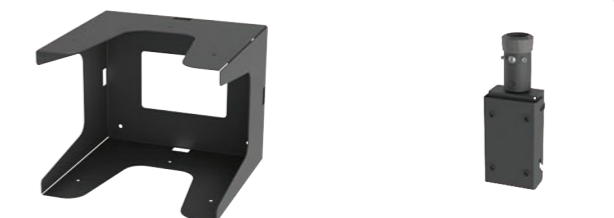

Example wall mount for Martin Audio SX-112.

Example ceiling suspension mount for Yamaha DXR12.

Call our sales team to discuss your requirements.





## NEW! Summit™ Video Conference Walls

Summit™ Video Conference Walls provide a neat and increasingly popular way of combining all the necessary elements of a video conferencing solution into a neat and aesthetically pleasing unit.

These highly adaptable video conference walls are custom designed to accommodate your choice of screen, video bar or camera plus speakers. All neatly packaged within an elegant freestanding unit.

Each unit is designed to support either single or twin screens up to 75", catering for most meeting room needs. Stretch display versions also available.

Versions include;

- Freestanding.
- Fixed position bolt down.
- Floor-to-wall fixed.
- Choice of colour finishes and accent panels.
- Branding and/or back illuminated options.



Call our sales team to discuss your requirements.



### Versatile Installation Options

Transform your meeting room presence with single or twin-screen freestanding, bolt down or floor-to-wall versions.



### Your Choice of AV Hardware

The Summit basic design concept makes it possible to perfectly integrate your choice of screen, video bar/camera or other AV equipment. Our custom design team with many years of experience working with consultants, integrators and end users has the capability of progressing the most demanding requirements through to a neat, elegant final design.



### Highly Customisable

Interchangeable panel options include wood finishes, acoustic fabric and corporate branding together with back illumination if required.



### Easy Installation

Easy access to populate the secure internal AV hardware space (typically AV equipment panels or standard 19" rack) allowing either on-site or prior to installation possibilities.

Call our sales team to discuss your requirements.

## Wide Ranging Applications in Sales, Room Booking Systems, Reception Areas & Much More

Utilise the flexibility and control offered by touch panels and tablets to streamline your day-to-day activities with our range of Tap.IT™ mounts.

Each Tap.IT™ version houses your touch panel in a steel shell for anti-tamper protection while allowing for ventilation, control button access, charge points etc. Anti-tamper screws available on request.

- Quick and easy assembly.
- PoE adapters can be accommodated.
- Configured for your choice of touch panel or tablet.

Please state tablet make and model when ordering.

Part Code & Description	Cost £ (Exc. VAT)	Screen Size	VESA Fixing (Min / Max)	Weight Capacity	Colour
TBM1   Dedicated Touch Panel Wall Mount (7 - 11")	120.40	7 - 11"	100x100	10kg	■ □
TBM2   Dedicated Touch Panel Wall Mount (12 - 15")	123.50	12 - 15"	100x100	10kg	■ □

## NEW! Touch Panel Stands

Add the appropriate tablet mount from the table above.

Part Code & Description	Cost £ (Exc. VAT)	Dimensions (H x W x Dmm)	Weight	Weight Capacity	Colour
TBP1   Touch Panel Stand (exc. TBM mount)	225.65	1060 x 330 x 300	9.5kg	5kg	■ □
TBBD1   Touch Panel Bolt Down Stand (exc. TBM mount)	225.65	1065 x 330 x 300	9.6kg	5kg	■ □

## NEW! Configure Your Own Tevella™ Single Column Tablet Stand

Add the appropriate tablet mount from the table above.

Product Image	Part Code & Description Specification	Cost £ (Exc. VAT)	Dimensions (H x W x Dmm)	Weight	Weight Cap.	Col.
	<b>TBMSCA   Single Column LECTERN Mount</b> Secures into a standard UNICOL column. For use with our TBM tablet mount range.	86.80	137 x 119 x 100	0.5kg	15kg	■ □
	<b>500   500mm Chrome Column</b>	16.25	500 x 50.8 x 50.8	0.9kg	n/a	●
	<b>1000   1000mm Chrome Column</b>	32.50	1000 x 50.8 x 50.8	1.8kg	n/a	●
	<b>LCP   Single Column Freestanding Base</b> All cabling can be routed through a column and the base providing a neat finish.	41.50	159 x 520 x 413	10kg	15kg	■ □
	<b>KT1   Single Column Trolley Base</b> Wheeled base for easy movement. All cabling can be routed through a column and the base.	162.46	272 x 600 x 560	7.0kg	15kg	■ □
	<b>LMB   Single Column LECTERN Base</b> All cabling can be routed through a column and base providing a neat finish.	101.50	167 x 500 x 500	9.5kg	15kg	■ □
	<b>LBP   Single Column Bolt Down Base</b> Fixed position base. All cabling can be routed through a column and the base.	85.10	167 x 295 x 240	4.1kg	15kg	■ □



Dedicated Touch Panel Wall Mount (TBM1)

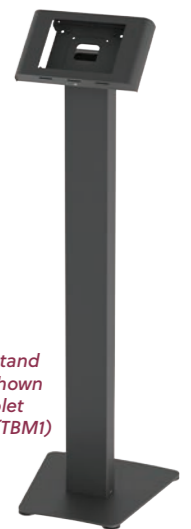

Tablet Stand (TBP1) shown with tablet mount (TBM1)



TBM1

TBMSCA

10000

KT1



## A Well-Proven & Flexible Range of Digital Signage Mounting Systems

Designed to meet the widely varying needs of corporate, retail display, airport or similar applications, and more.

Choose between our twin chrome column Obelisk™ range, listed below, or EdgeLine™ range listed on pages 36-37. Each range offers a wide choice of styles. All are designed and manufactured to perfectly fit each screen make and model.

- Rapid turnaround.
- Space for players, PC's, video conference cameras etc.
- Polycarbonate protective screen options.
- Finished in standard Sinterflex Black (■) with custom colour finishes and corporate branding at extra cost.

*Please state screen make and model when ordering. Please note: prices quoted are ex-works as this unit is despatched by dedicated courier or may be collected. Images are illustrative and final product may vary slightly from what is shown.*

### Freestanding & Bolt Down Kiosks

- Single sided & back-to-back versions listed.
- Quick and simple to install.



Freestanding

Bolt Down

### Freestanding & Bolt Down Totems

- Single sided & back-to-back versions listed.
- Quick and simple to install.



Freestanding

Bolt Down

Part Code & Description	Cost £ (Exc. VAT)	Screen Size
KTC3FS   Freestanding Kiosk (Single Sided)	921.20	30 - 39"
KTC3FSB   Freestanding Kiosk (Back-to-Back)	1096.15	
KTC3BD   Bolt Down Kiosk (Single Sided)	824.30	40 - 49"
KTC3BDB   Bolt Down Kiosk (Back-to-Back)	999.40	
KTC4FS   Freestanding Kiosk (Single Sided)	1002.52	50 - 59"
KTC4FSB   Freestanding Kiosk (Back-to-Back)	1177.52	
KTC4BD   Bolt Down Kiosk (Single Sided)	905.78	60 - 69"
KTC4BDB   Bolt Down Kiosk (Back-to-Back)	1080.78	
KTC5FS   Freestanding Kiosk (Single Sided)	1125.72	70 - 79"
KTC5FSB   Freestanding Kiosk (Back-to-Back)	1300.72	
KTC5BD   Bolt Down Kiosk (Single Sided)	1027.65	
KTC5BDB   Bolt Down Kiosk (Back-to-Back)	1200.72	
KTC6FS   Freestanding Kiosk (Single Sided)	1205.85	
KTC6FSB   Freestanding Kiosk (Back-to-Back)	1380.85	
KTC6BD   Bolt Down Kiosk (Single Sided)	1107.55	
KTC6BDB   Bolt Down Kiosk (Back-to-Back)	1380.62	
KTC7FS   Freestanding Kiosk (Single Sided)	1518.56	
KTC7FSB   Freestanding Kiosk (Back-to-Back)	1693.56	
KTC7BD   Bolt Down Kiosk (Single Sided)	1437.56	
KTC7BDB   Bolt Down Kiosk (Back-to-Back)	1612.56	

Part Code & Description	Cost £ (Exc. VAT)	Screen Size
KTC3FST   Freestanding Totem (Single Sided)	1413.15	30 - 39"
KTC3FSTB   Freestanding Totem (Back-to-Back)	1588.20	
KTC3BDT   Bolt Down Totem (Single Sided)	1372.15	40 - 49"
KTC3BDTB   Bolt Down Totem (Back-to-Back)	1547.15	
KTC4FST   Freestanding Totem (Single Sided)	1494.63	50 - 59"
KTC4FSTB   Freestanding Totem (Back-to-Back)	1669.63	
KTC4BDT   Bolt Down Totem (Single Sided)	1453.65	60 - 69"
KTC4BDTB   Bolt Down Totem (Back-to-Back)	1628.65	
KTC5FST   Freestanding Totem (Single Sided)	1559.50	70 - 79"
KTC5FSTB   Freestanding Totem (Back-to-Back)	1734.50	
KTC5BDT   Bolt Down Totem (Single Sided)	1505.36	
KTC5BDTB   Bolt Down Totem (Back-to-Back)	1680.36	
KTC6FST   Freestanding Totem (Single Sided)	1616.85	
KTC6FSTB   Freestanding Totem (Back-to-Back)	1791.85	
KTC6BDT   Bolt Down Totem (Single Sided)	1552.35	
KTC6BDTB   Bolt Down Totem (Back-to-Back)	1727.35	
KTC7FST   Freestanding Totem (Single Sided)	1865.60	
KTC7FSTB   Freestanding Totem (Back-to-Back)	2040.60	
KTC7BDT   Bolt Down Totem (Single Sided)	1829.65	
KTC7BDTB   Bolt Down Totem (Back-to-Back)	2004.65	



Example 55" Freestanding Kiosk (KTC5FS)

### Floor-to-Ceiling Kiosks

- Single sided & back-to-back versions listed.
- Provided with 3m columns as standard with other lengths available if required.
- Quick and simple to install.
- Cabling can be routed through the columns and ceiling plates.



Part Code & Description	Cost £ (Exc. VAT)	Screen Size
KTC3FC   Floor-to-Ceiling (Single Sided)	1004.20	30 - 39"
KTC3FCB   Floor-to-Ceiling (Back-to-Back)	1179.15	
KTC4FC   Floor-to-Ceiling (Single Sided)	1085.66	40 - 49"
KTC4FCB   Floor-to-Ceiling (Back-to-Back)	1260.66	
KTC5FC   Floor-to-Ceiling (Single Sided)	1225.26	50 - 59"
KTC5FCB   Floor-to-Ceiling (Back-to-Back)	1400.26	
KTC6FC   Floor-to-Ceiling (Single Sided)	1344.55	60 - 69"
KTC6FCB   Floor-to-Ceiling (Back-to-Back)	1419.55	
KTC7FC   Floor-to-Ceiling (Single Sided)	1555.32	70 - 79"
KTC7FCB   Floor-to-Ceiling (Back-to-Back)	1730.32	

### Flexible Customisation

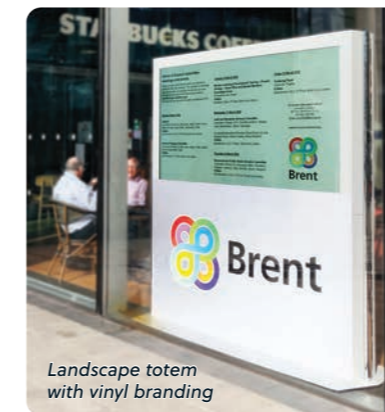

Landscape totem with vinyl branding



Standard kiosk with retail analytics camera hole



Totem with cut-outs for scanning & issuing tickets

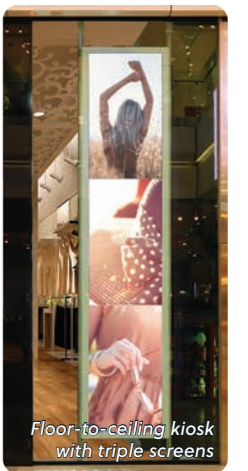

Floor-to-ceiling kiosk with triple screens

## NEW! Mobile Obelisk™ Kiosks & Totems

Neat castor wheeled base provides freedom of movement for your digital signage totem from area to area with ease.

Available in both kiosk and totem styles and suitable for single screen or back-to-back versions. Each are designed and manufactured to perfectly fit your screen make and model.

- Discreet castor base provides mobility in situations where freedom of movement is desired.
- Space for players, PC's, video conference cameras etc.
- Polycarbonate protective screen options.
- Rapid turnaround.
- Finished in standard Sinterflex Black (■) with custom colour finishes and corporate branding at extra cost.

*Please state screen make and model when ordering. Please note: prices quoted are ex-works as this unit is despatched by dedicated courier or may be collected. Images are illustrative and final product may vary slightly from what is shown.*

Call our sales team to discuss your requirements.



Example 55" Wheeled Totem



## A Well-Proven & Flexible Range of Digital Signage Mounting Systems

Designed to meet the widely varying needs of corporate, retail display, airport or similar applications, and more.

Choose between our EdgeLine™ range, listed below, or twin chrome column Obelisk™ range listed on pages 34-35. Each range offers a wide choice of styles. All are designed and manufactured to perfectly fit each screen make and model.

- Rapid turnaround.
- Space for players, PC's, video conference cameras etc.
- Polycarbonate protective screen options.
- Finished in standard Sinterflex Black (■) with custom colour finishes and corporate branding at extra cost.

*Please state screen make and model when ordering. Please note: prices quoted are ex-works as this unit is despatched by dedicated courier or may be collected. Images are illustrative and final product may vary slightly from what is shown.*

### Freestanding & Bolt Down Kiosks

- Single sided & back-to-back versions listed.
- Quick and simple to install.



Part Code & Description	Cost £ (Exc. VAT)	Screen Size
EKTC3FS   Freestanding Kiosk (Single Sided)	971.08	30 - 39"
EKTC3BD   Bolt Down Kiosk (Single Sided)	864.30	30 - 39"
EKTC4FS   Freestanding Kiosk (Single Sided)	1060.70	40 - 49"
EKTC4BD   Bolt Down Kiosk (Single Sided)	954.09	40 - 49"
EKTC5FS   Freestanding Kiosk (Single Sided)	1196.46	50 - 59"
EKTC5BD   Bolt Down Kiosk (Single Sided)	1088.39	50 - 59"
EKTC6FS   Freestanding Kiosk (Single Sided)	1284.77	60 - 69"
EKTC6BD   Bolt Down Kiosk (Single Sided)	1174.31	60 - 69"
EKTC7FS   Freestanding Kiosk (Single Sided)	1629.37	70 - 79"
EKTC7BD   Bolt Down Kiosk (Single Sided)	1540.11	70 - 79"

### Ceiling Suspended Kiosks

- Single sided versions listed, back-to-back available on request.
- Quick and simple to install.



Part Code & Description	Cost £ (Exc. VAT)	Screen Size
EKTC3CS   Ceiling Suspended Kiosk (Single Sided)	POA	30 - 39"
EKTC4CS   Ceiling Suspended Kiosk (Single Sided)	POA	40 - 49"
EKTC5CS   Ceiling Suspended Kiosk (Single Sided)	POA	50 - 59"
EKTC6CS   Ceiling Suspended Kiosk (Single Sided)	POA	60 - 69"
EKTC7CS   Ceiling Suspended Kiosk (Single Sided)	POA	70 - 79"

### Freestanding & Bolt Down Totems

- Single sided & back-to-back versions listed.
- Quick and simple to install.



Part Code & Description	Cost £ (Exc. VAT)	Screen Size
EKTC3FST   Freestanding Totem (Single Sided)	1513.21	30 - 39"
EKTC3BDT   Bolt Down Totem (Single Sided)	1468.03	30 - 39"
EKTC4FST   Freestanding Totem (Single Sided)	1603.00	40 - 49"
EKTC4BDT   Bolt Down Totem (Single Sided)	1557.84	40 - 49"
EKTC5FST   Freestanding Totem (Single Sided)	1674.49	50 - 59"
EKTC5BDT   Bolt Down Totem (Single Sided)	1614.83	50 - 59"
EKTC6FST   Freestanding Totem (Single Sided)	1737.63	60 - 69"
EKTC6BDT   Bolt Down Totem (Single Sided)	1666.61	60 - 69"
EKTC7FST   Freestanding Totem (Single Sided)	2011.81	70 - 79"
EKTC7BDT   Bolt Down Totem (Single Sided)	1972.19	70 - 79"

### Freestanding & Bolt Down Kiosks for Double Sided Displays

- Ideal for Samsung OMN-D range.
- Quick and simple to install.



Part Code & Description	Cost £ (Exc. VAT)	Screen Size
ODS46FS   46" Double-Sided Freestanding Kiosk	646.60	46"
ODS46BD   46" Double-Sided Bolt Down Kiosk	646.60	46"
ODS55FS   55" Double-Sided Freestanding Kiosk	695.10	55"
ODS55BD   55" Double-Sided Bolt Down Kiosk	695.10	55"

## NEW! LED EdgeLine™ Totems

Expanding on our popular kiosk and totem ranges to now include LED tile technology. Ideal for retail and exhibition settings, these innovative LED totems unlock a multitude of possibilities where LED tiles are chosen as the medium for digital signage.

Based on our well-proven EdgeLine™ range, these totems deliver an aesthetically pleasing solution. Each are designed to accommodate any desired array of LED tile system.

- Exactly tailored to each LED tile system.
- Easy assembly to aid installation.
- Freestanding or bolt down versions offer mobile or fixed placement as required.
- Finished in standard Sinterflex Black (■) with custom colour finishes and corporate branding available at extra cost.
- Seamless design - no visible fixings.

*Please state LED make and model when ordering.*

Call our sales team to discuss your requirements.

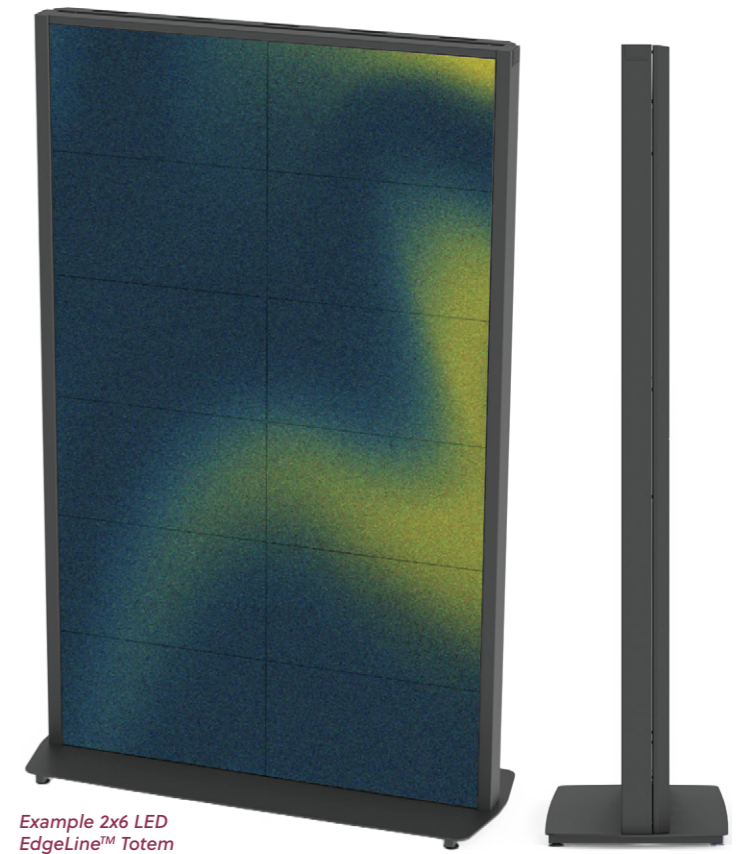

Example 2x6 LED EdgeLine™ Totem

## NEW! Roller Trak™ EdgeLine™ Kiosks

Utilising our AV Roller Trak™ System (see page 41), kiosks smoothly glide on ball bearing track system, with various length option available. Ideal for retail and other applications. Displays can be tracked either in & out or side to side depending on application. Ideal for window displays, servicing needs or simple access for cleaning.

### Multi-Adjustable Point of Sale Advertising

Ideal for window displays, giving your digital signage complete mobility and total flexibility for changing window displays or simply for screen maintenance or periodic window cleaning.



Example 55" Roller Trak™ EdgeLine™ Kiosk with Side to Side Adjustment

Call our sales team to discuss your requirements.



## Outdoor Housings for Harsh Environments to IP53

UNICOL pioneered the development of outdoor housings and has unrivalled experience in this specialised field. Our well-proven range of housings go from small screen monitors used in harsh environments right up to the latest 86 inch large format screens.

All are constructed in 1050 grade aluminium and utilise high quality temperature controlling components within. Screen viewing panels in impact resistant polycarbonate are incorporated as standard. Toughened or laminated glass also available as an option.

- Tailor made for perfect screen fit every time.
- Caters for a wide range of screen sizes.
- IP53 rated with vandal resistant screen.
- Corrosion free for long life in all weathers.
- Light weight aluminium construction.
- Wall, ceiling or back-to-back mountable.
- Thermostatic internal heating and cooling.
- User replaceable air filtration cartridge.
- CE approved.

*Please Note: prices quoted are ex-works as these are despatched by dedicated courier or may be collected. Please state screen make and model when ordering. Images are illustrative and final product may vary slightly from what is shown.*



Example Outdoor Housing

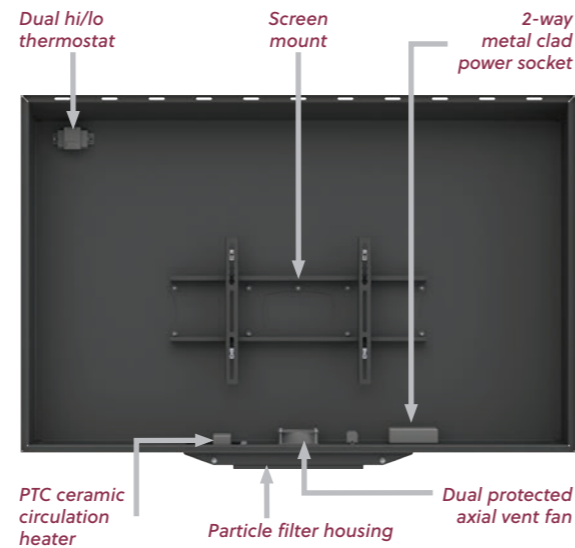

### Outdoor Housing Range as follows:

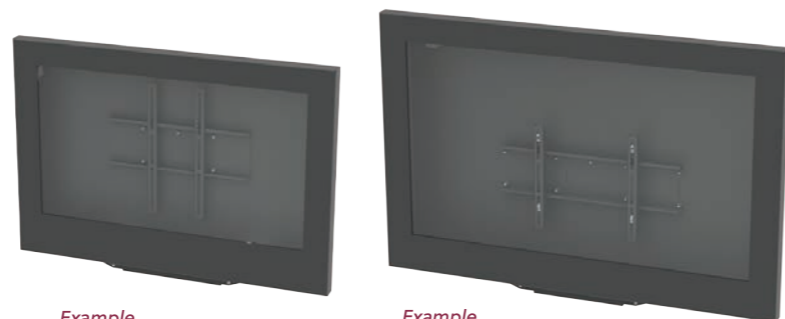

Example ODH1

Example ODH2

Part Code & Description	Cost £ (Exc. VAT)	Screen Size	Col.
ODH0   30 - 32" Outdoor Housing (Landscape or Portrait)	1420.10	30 - 32"	■
ODH1   33 - 57" Outdoor Housing (Landscape or Portrait)	1530.80	33 - 57"	■
ODH2   58 - 70" Outdoor Housing (Landscape or Portrait)	1610.70	58 - 70"	■
ODH3   71 - 80" Outdoor Housing (Landscape or Portrait)	2690.70	71 - 80"	■
ODH4   81 - 86" Outdoor Housing (Landscape or Portrait)	3520.80	81 - 86"	■
ODH5   87" + Outdoor Housing (Landscape or Portrait)	POA	87"+	■

## NEW! Bolt Down Floor Standing Versions



Call our sales team to discuss your requirements.



## Anti-Shatter Protective Covers

5mm thick, clear, anti-shatter screen combine with an all metal bezel to provide a durable protective cover for screens. Available as either clip-on or wall mounted. Each cover is tailor-made for each screen make and model.

Colour options, anti-reflective screens, branding and bespoke versions available as well as ceiling suspended options.

For portrait versions, use 'PCP' instead of 'PCL' below.



Example Landscape Wall Mounted Cover

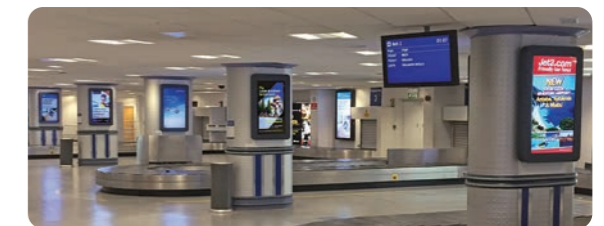

## NEW! 2x1 and 1x2 Cover Variations

Dual screen PCL/PCP covers are available upon request. Call to discuss your requirements.

*Please state screen make and model when ordering. Please Note: PCL9 & PCL13 are quoted ex-works as these are despatched by dedicated courier or may be collected. Images are illustrative and final product may vary slightly from what is shown.*

Part Code & Description	Cost £ (Exc. VAT)	Dimensions (H x W x Dmm)	Weight	Screen Size	Weight Capacity	Colour
PCL0   15 - 32" Landscape Clip-On Cover (Square Corners)	255.00	variable	variable	15 - 32"	n/a	■
PCL1   33 - 57" Landscape Clip-On Cover (Square Corners)	288.40	variable	variable	33 - 57"	n/a	■
PCL2   58 - 70" Landscape Clip-On Cover (Square Corners)	346.10	variable	variable	58 - 70"	n/a	■
PCL5   15 - 32" Landscape Wall Mounted Cover (Square Corners)	540.80	variable	variable	15 - 32"	60kg	■
PCL7   33 - 57" Landscape Wall Mounted Cover (Square Corners)	574.40	variable	variable	33 - 57"	60kg	■
PCL8   58 - 70" Landscape Wall Mounted Cover (Square Corners)	632.10	variable	variable	58 - 70"	60kg	■
PCL9   71 - 75" Landscape Wall Mounted Cover (Square Corners)	689.80	variable	variable	71 - 75"	60kg	■
PCL10   15 - 32" Landscape Wall Mounted Cover (Round Corners)	865.20	variable	variable	15 - 32"	60kg	■
PCL11   33 - 57" Landscape Wall Mounted Cover (Round Corners)	898.40	variable	variable	33 - 57"	60kg	■
PCL12   58 - 70" Landscape Wall Mounted Cover (Round Corners)	956.10	variable	variable	58 - 70"	60kg	■
PCL13   71 - 75" Landscape Wall Mounted Cover (Round Corners)	1065.90	variable	variable	71 - 75"	60kg	■

## Custom Rear Covers

We design and manufacture custom rear covers for a wide range of screen sizes. These provide a neat appearance so that cables & connections remain hidden when screens are installed in open areas. Full screen versions or partial covers to enclose cables & connections areas are available.

*Please state screen make and model when ordering. Please Note: BCW3 is quoted ex-works as these are despatched by dedicated courier or may be collected. Images are illustrative and final product may vary slightly from what is shown.*

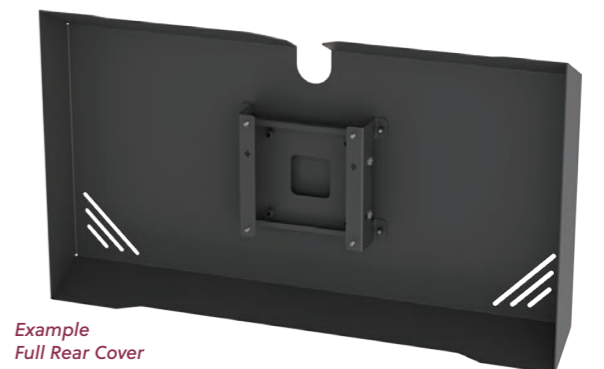

Example Full Rear Cover

Part Code & Description	Cost £ (Exc. VAT)	Dimensions (H x W x Dmm)	Weight	Screen Size	Weight Capacity	Colour
BCX1   33 - 57" Full Rear Cover inc. Screen Mount (Landscape or Portrait)	517.50	variable	variable	33 - 57"	n/a	■
BCX2   58 - 70" Full Rear Cover inc. Screen Mount (Landscape or Portrait)	617.60	variable	variable	58 - 70"	n/a	■
BCX3   71 - 75" Full Rear Cover Inc. Screen Mount (Landscape or Portrait)	794.10	variable	variable	71 - 75"	n/a	■



## Multi-Screen Ceiling Suspended Gantry Systems

These ceiling mounted units are available for a wide range of screen sizes by partnering with our Pozimount universal tilting screen mounts. The spider style and single column gantry versions have swivel capability and cable entry ports for neat installation.

Part codes and prices are listed as a reference guide. We highly recommend discussing gantry installations with our project team to confirm configurations.

### Spider Gantries

- Available in 3, 4 or 5 screen frame options.
- Utilise our universal tilting mounts with patented finger tip tilt control mechanism that makes viewing angle easy to set (0° to 11°).
- Check screen width requirements before ordering.



Complete 3-Screen Spider Gantry Solution

Part Code & Description	Cost £ (Exc. VAT)	Dimensions (H x W x Dmm)	Weight	Weight Capacity	Colour
CP5   Gantry Ceiling Plate (see page 28 for more info)	108.40	176 x 540 x 540	4.8kg	270kg	■
1000HC   1000mm Heavy Duty Ceiling Suspension Chrome Column	43.10	1000 x 50.8 x 50.8	3.0kg	n/a	●
2000HC   2000mm Heavy Duty Ceiling Suspension Chrome Column	86.20	2000 x 50.8 x 50.8	6.0kg	n/a	●
3000HC   3000mm Heavy Duty Ceiling Suspension Chrome Column	129.30	3000 x 50.8 x 50.8	9.0kg	n/a	●
SG3   3 Screen Spider Gantry Frame (up to 57" / screen width: 975-1300mm)	462.90	277 x 576-738 x 516-640	11.6kg	50kg*	■
SG4   4 Screen Spider Gantry Frame (up to 57" / screen width: 975-1300mm)	617.20	277 x 868-1348 x 868-1348	17.7kg	50kg*	■
SG5   5 Screen Spider Gantry Frame (up to 57" / screen width: 975-1300mm)	770.00	277 x 1224-1862 x 1164-1771	24.0kg	40kg*	■
PZW1   200x200 to 600x400 VESA Universal Mount (see page 23 for more info)	118.40	535 x 765 x 64-115	6.2kg	60kg	■

\*max weight per screen

### Inline Gantries

- Suitable for single sided or back-to-back 2x1 & 3x1 inline screen displays - ideal for menu boards.
- Utilise our universal tilting mounts with patented finger tip tilt control mechanism that makes viewing angle easy to set (0° to 11°).



Example 2x1 Single Column Inline Gantry Solution

Part Code & Description	Cost £ (Exc. VAT)	Dimensions (H x W x Dmm)	Weight	Weight Capacity	Colour
CP2   Large Standard Ceiling Plate (see page 28 for more info)	42.90	122 x 272 x 272	2.7kg	120kg	■
1000HC   1000mm Heavy Duty Ceiling Suspension Chrome Column	43.10	1000 x 50.8 x 50.8	3.0kg	n/a	●
2000HC   2000mm Heavy Duty Ceiling Suspension Chrome Column	86.20	2000 x 50.8 x 50.8	6.0kg	n/a	●
3000HC   3000mm Heavy Duty Ceiling Suspension Chrome Column	129.30	3000 x 50.8 x 50.8	9.0kg	n/a	●
MSP1   Bolt On Peg (Connects inline frames with KPICB/KPIDB)	14.00	110 x 65 x 65	0.4kg	n/a	■
MSS1   Bolt On Socket (Connects inline frames with column lengths)	17.00	121 x 70 x 70	0.8kg	n/a	■
DIG1050   100 - 500mm Inline Gantry Frame (up to 57")	75.60	66 x 593 x 82	3.9kg	30kg*	■
DIG50100   500 - 1000mm Inline Gantry Frame (up to 57")	75.60	66 x 1100 x 82	7.7kg	30kg*	■
DIG100150   1000 - 1500mm Inline Gantry Frame (up to 57")	75.60	66 x 1600 x 82	11.5kg	30kg*	■
DIG150200   1500 - 2000mm Inline Gantry Frame (up to 57")	75.60	66 x 2100 x 82	14.8kg	30kg*	■
KPICB   Tilting Ceiling Suspension Mount inc. PZW1 (33 - 70" / single sided)	153.80	540 x 765 x 96	7.7kg	60kg	■
KPIDB   Tilting Ceiling Suspension Mount inc. PZW1 (33 - 70" / back-to-back)	289.60	540 x 765 x 128-230	14.3kg	45kg*	■

\*max weight per screen

## The Moving Track System for Digital Displays in Retail & Other Applications

Ideal for retail and other applications. Displays can be tracked either in & out or side to side depending on application. Give your digital signage complete mobility and total flexibility when changing window displays or simply carrying out screen maintenance or periodic window cleaning.

AV Roller Trak™ systems consist of standardised track lengths, standard UNICOL column lengths & screen mounts. Kiosk versions available, see page 37.

- Smooth, easy operation.
- Single or multiple screens with LED solutions also available.
- Range of installation options including ceiling suspended, floor-to-ceiling and floor mounted.
- Wide choice of track lengths with in-out and side-to-side movement options.
- Swivel or RotaMount™ options available.
- Highly adaptable solution with a wide range of custom opportunities available.



Example Multi-Screen, Floor-to-Ceiling, Pop-Out Video Wall Mounts with In-Out AV Roller Trak™



Example Ceiling Suspended EdgeLine Kiosk with Side-to-Side Roller Trak. See Page 37.



Example Ceiling Suspended RotaMount with Side-to-Side Roller Trak

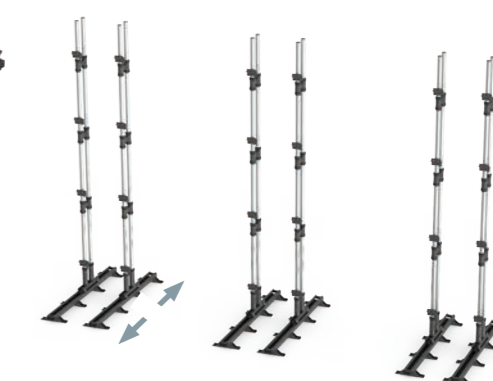

Example Floor Mounted LED Video Wall with In-Out Roller Trak

### In-Situ AV Roller Trak™ Example

The end user wanted to be able to alter the screen in their window display to suit each unique design. Utilising a side-to-side moving AV Roller Trak™ with a dedicated rotating mount, the end user is able to move the screen around mannequins and window stickers and also smoothly transition from portrait to landscape.

Offers a plethora of window advertising and layout opportunities, easy to use with almost finger tip movement.





## NEW! Dedicated LED Mounts

Taking projects through to a successful conclusion is a major part of what UNICOL does. We work with a wide range of respected clients in the world of Education, the Corporate sector, Government and Industry.

This page shows just a small selection of some recent projects. From individual custom-made freestanding totems to large scale screen and LED tile displays. These have been floor mounted, ceiling suspended, or on structural building columns.

- Close client support between integrators, end users and the UNICOL design team, from concept through to delivery.
- Short lead times.
- Design philosophy that ensures easy installation.
- Branding, colour options and much more.

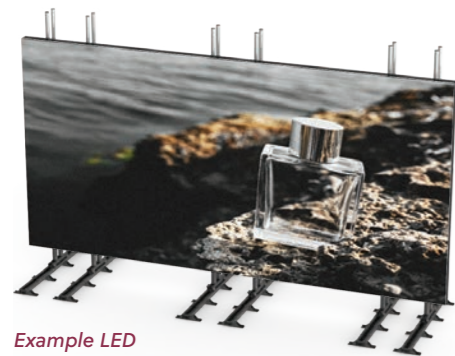

Example LED Roller-Trak Video Wall



Example 2x6 LED Freestanding Totem

### Roller-Trak™ LED Video Walls

Ideal for window displays, servicing needs or simple access. See page 41 for more info.

### LED Freestanding Totems

Ideal for retail and exhibition settings where LED tiles are used. See page 37 for more info.



### Bespoke Installations

Transform your space with our custom designed LED video wall installations, each faithfully carried through from concept to final delivery. Our long experienced design team is geared to offer advice, arrange site visits and more, to ensure the success of every project.

## NEW! All-In-One Mounts

Dedicated to all-in-one screens from 110" up to 200" and available in floor-to-wall, floor-to-ceiling and ceiling suspended.

These mounts embody many innovative design features including concealed cable management, precise screen alignment, and in the case of the floor-to-ceiling and suspended versions, ability to cope with high or even sloping ceilings.

- Wide range of installation options.
- Easy ordering & fast turnaround available.
- For all-in-one displays from 110" to 200".
- Adaptable for custom add-ons, speakers & more.
- Ideal for Optoma, LG, Viewsonic and most other all-in-one screens.



Example Floor-to-Wall All-in-One Mount (FWUHD)



Example Ceiling Suspended All-in-One Mount (KPUHD3CB)

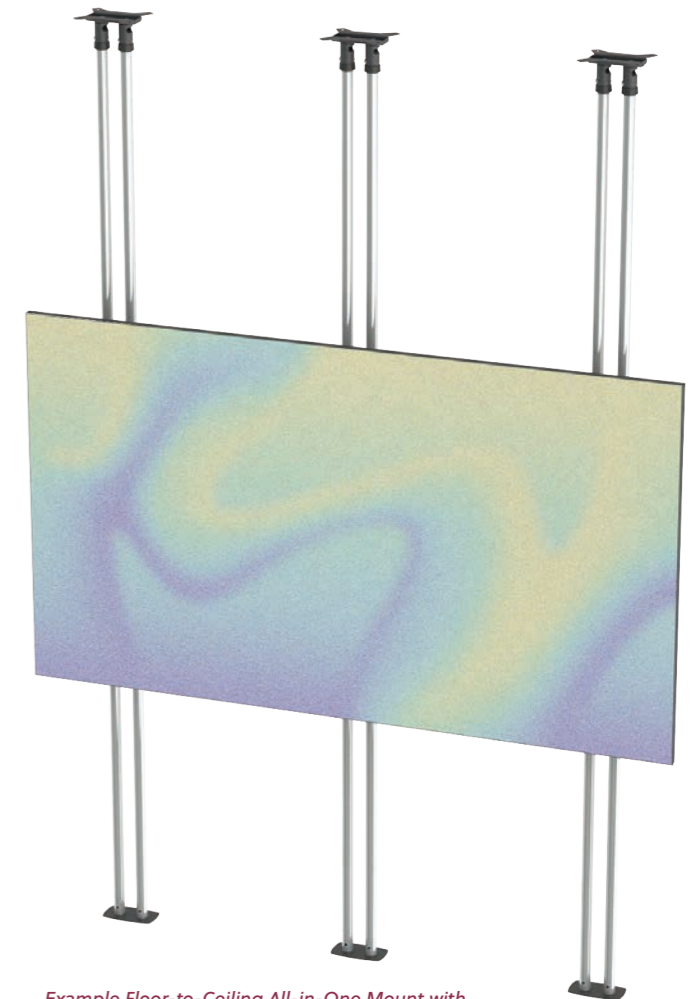

Example Floor-to-Ceiling All-in-One Mount with Sample All-in-One LED Screen (FCUHD)

Please state LED tile make and model when ordering. Our All-in-One LED product range is subject to continuous development. Final products may therefore vary slightly from illustration shown.

Part Code & Description	Cost £ (Exc. VAT)	Dimensions (H x W x Dmm)	Weight	Screen Size	Colour
FCUHD   Floor-to-Ceiling All-in-One LED Mount	POA	4120 x 2800 x 261	135.8kg	110 - 200"	■
FWUHD   Floor-to-Wall All-in-One LED Mount	POA	2597 x 2800 x 242	110.1kg	110 - 200"	■
KPUHD3CB   Ceiling Suspended All-in-One LED Mount	POA	2720 x 2800 x 358	111.4kg	110 - 200"	■

### Flying Digital Signage Flags

UNICOL collaborated with 21st Century AV to enhance Brent Council's main atrium with large-scale LED digital signage resembling hoisted flags. The bespoke 1.5x4m LED solutions were vertically suspended from concrete pillars, accommodating Absen A2725 Plus LED panels and featuring a polyester fabric panel with the Brent Council logo. Overcoming structural challenges, the project successfully integrated the technology without compromising aesthetics. Installed quickly over one weekend, the four LED flag-style displays provide a unique and impactful entrance to the council center, meeting Brent Council's AV needs while maintaining the building's aesthetics.



Read the full case study at; [unicol.com/knowledgehub](http://unicol.com/knowledgehub)

## NEW! UNICOL Mobile Phone Holders

A fun addition to our product range.

What started out as a one-off promotional giveaway has proved so popular we have been asked to include it in our product range with many being requested in house colours and branding where sufficient volumes allow.

Part Code & Description	Cost £ (Exc. VAT)	Colour
UPH1   Mobile Phone Holder (minimum order quantity x25)	10.99	■ □





## Installer Friendly, Innovative Pop-Out Mounts

The Adapta-Wall® encourages ease when installing, maintaining or changing screens with its micro-adjustment arms and pop-out operation. These installer friendly pop-out video wall mounts utilise 'push-to-close – push-to-open' action as standard.

When fully open, this range offers ample room to adjust and maintain screens, cabling and positioning. These mounts offer horizontal and vertical fine adjustment to allow for accurate levelling post-installation.

Remote latching also available for thin or delicate displays, please call or enquire for more information.

Patent Pending. Registered Design®

### 'Push-to-Close - Push-to-Open' Action

Easily access small devices located at the rear of a screen with our pop-out mounts. Ideal for screens that are installed in alcoves, tight places, or as a part of a video wall display. Gently push on both sides of the screen bezel to unlatch the pop-out mechanism.

### Accurate Installs with Fine Screen Levelling

Each Adapta-Wall® mount comes with tool-less fully adjustable arms as standard. These arms feature 15mm in-out adjustment and 15mm of fine levelling adjustment. Side-to-side adjustment included and varies on width of screen mount.



Standard Adapta-Wall® Pop-Out Mount - Open (VWP1)

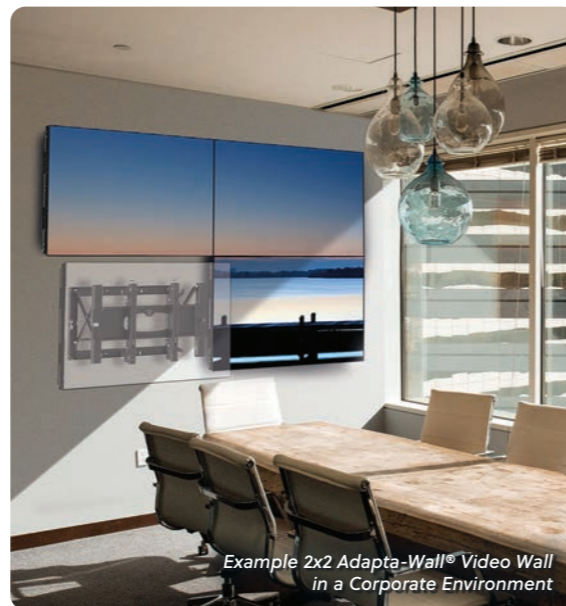

Example 2x2 Adapta-Wall® Video Wall in a Corporate Environment



VWP0

VWP1

VWP2

VWP3

Part Code & Description	Cost £ (Exc. VAT)	Dimensions (H x W x Dmm)	Weight	Screen Size	VESA Fixing (Min / Max)	Weight Capacity	Colour
VWP0   Compact Adapta-Wall® Pop-Out Mount	318.50	300 x 410 x 70-262	7.7kg	33 - 40"	100x100 / 200x200	45kg	■
VWP1   Standard Adapta-Wall® Pop-Out Mount	347.80	500 x 800 x 103-340	14.5kg	33 - 70"	300x300 / 600x400	45kg	■
VWP2   Large Portrait Adapta-Wall® Pop-Out Mount	354.60	716 x 500 x 103-340	13.0kg	33 - 70"	300x300 / 400x600	45kg	■
VWP4   Small Portrait Adapta-Wall® Pop-Out Mount	354.60	500 x 500 x 103-340	12.2kg	33 - 70"	300x300 / 400x400	45kg	■
VWP3   Large Adapta-Wall® Pop-Out Mount	362.20	500 x 800 x 132-370	14.1kg	33 - 70"	300x300 / 800x400	45kg	■
VWPHD   Heavy Adapta-Wall® Duty Pop-Out Mount	565.30	500 x 800 x 73-340	16.3kg	71 - 90"	300x300 / 600x400	80kg	■

## Pop-Out Video Wall Structures

The Adapta-Wall® video structure system is designed for use with our Adapta-Wall® pop-out mounts (left) where direct wall fixing is not applicable. Ceiling, floor-to-ceiling and floor-to-wall structures can be easily constructed using multiples of the parts listed below.

Part codes and prices are listed as a reference guide only. We highly recommend discussing video wall structures with our project team to confirm configurations.



Example 3x3 Floor-to-Wall Adapta-Wall® Video Wall Structure. Picture courtesy of 21<sup>st</sup> Century AV.

Product Image	Part Code & Description	Cost £ (Exc. VAT)	Dimensions (H x W x Dmm)	Weight	Colour
	VWPA10   Quad Column Ceiling Plate	145.50	117 x 424 x 315	4.9kg	■
	VWPA11   Quad Column Floor Plate	140.50	160 x 424 x 315	6.0kg	■
	VWPA1   Column Tie Brace Units (pack of 2)	98.20	120 x 262 x 72	3.2kg	■
	VWPA2   Twin Column Ceiling Plate	86.80	117 x 400 x 160	2.9kg	■
	VWPA4   Twin Column Floor Plate	92.30	207 x 400 x 150	4.4kg	■
	VWPA9   Twin Column Wall Plate	97.50	72 x 410 x 129	1.6kg	■
	VWPA5   Mount 'U'-Clamps (pack of 4)	82.50	50 x 105 x 63	0.8kg	■

## Freestanding Video Wall System

The V-Wall is ideal for situations when quick, easy and accurate assembly is required such as in hire and retail, where regular change is inevitable.

This robust modular structure is made of individual mast units that are joined with cross members enabling a 3 or 4-high display unit to have infinite width. Cable management runs are catered for and there is adequate space for PC's and other devices.

- Robust modular construction.
- Easy to assemble and install.
- Range of installation options inc. floor-to-wall, freestanding and bolt down.
- Discreet cable management with ample storage space.
- Tool-less fine adjustment levelling.
- Max. weight capacity of 45kg per screen.
- Typically suits 40 - 55" screens.



Example 3x3 V-Wall Structure

Call our sales team to discuss your requirements.

Please note: prices quoted are ex-works as this unit is despatched by dedicated courier or may be collected. Please state screen make and model when ordering.

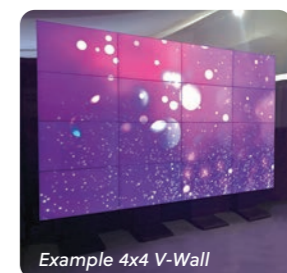

Example 4x4 V-Wall



Custom 3x3 V-Wall



## Single Screen Table Stands

These table stands provide a small footprint for table-top screens up to 110". Provided with a universal Pozimount mount as standard, this solution covers a wide range of VESA fixings allowing you to easily change/replace screens when necessary. The stand mast features multiple fixing points to provide adjustment for screen size variation.

Dedicated versions are available upon request.

- Feature resilient non-marking feet.
- Universal mount supplied as standard.
- Height adjustment built-in to each mast.
- Caters for a wide range of VESA fixings.

Please state screen make and model when ordering. Call for any advice or assistance as required.



Universal Table Stand Inc. PZX1 (PFT1)

Part Code & Description	Cost £ (Exc. VAT)	Dimensions (H x W x Dmm)	Weight	Screen Size	VESA Fixing (Min / Max)	Weight Cap.	Col.
PFT3   Universal Stand inc. PZX3 (Screen Centre: 420-520mm)	225.60	620 x 626 x 270	14.8kg	32 - 57"	200x200 / 400x400	60kg	■
PFT1   Universal Stand inc. PZX1 (Screen Centre: 420-520mm)	225.60	620 x 626 x 270	16.6kg	40 - 70"	200x200 / 600x400	60kg	■
PFT9   Universal Stand inc. PZX9 (Screen Centre: 750mm)	289.35	1096 x 1300 x 430	44.0kg	71 - 110"	300x300 / 1000x600	60kg	■
PFT10   Universal Stand inc. PZX10 (Screen Centre: 750mm)	490.36	1275 x 1600 x 430	53.1kg	71 - 110"	400x600 / 1500x600	60kg	■

## Seated or Standing Collaborative Meeting Tables

The Huddle and Stand-to-Meet collaborative tables are designed to integrate seamlessly with meeting technology.

The Huddle can be powered up and down at the push of a button. Transition between seated or standing meetings seamlessly. Whilst the Stand-to-Meet is a fixed height collaborative table, perfect for brief meetings/hot-desking.

Both styles offer ample capacity for cabling and integration with other systems, all accessible through a cable well and locking door. Built in 4-way power socket as standard.

Branding, alternative table top finishes and custom cut-outs on the table top available upon request.

Please note: prices quoted are ex-works as this unit is despatched by dedicated courier or may be collected. Please state screen make and model when ordering.



Huddle Single Screen Height Adjustable Table (RHO2)

Part Code & Description	Cost £ (Exc. VAT)	Dimensions (H x W x Dmm)	Weight	Screen Size	VESA Fixing (Min / Max)	Weight Capacity	Colour
RHO1   Huddle Single Screen Height Adjustable Table	3850.00	variable	variable	33 - 70"	200x200 / 600x400	60kg	■
RHO2   Huddle Twin Screen Height Adjustable Table	4150.00	variable	variable	33 - 70"	200x200 / 600x400	35kg*	■
RS01   Stand-to-Meet Twin Screen Fixed Height Table	3978.30	variable	variable	33 - 70"	200x200 / 600x400	35kg*	■
RSU01   Underside Custom Controller/Switcher Unit	728.10	variable	variable	n/a	n/a	n/a	■
RSU02   Large Front Mast for Cable Cubby with Retractors	125.50	variable	variable	n/a	n/a	n/a	■

## Stylish, Free Standing Lecterns

The Canterbury™ is a versatile lectern that provides secure storage for media electronics with 19" 16U rack mounting as standard. Stylish oval cabinet has concealed castors with jacking feet for extra stability on uneven surfaces. The range of durable desk tops are available in a choice of sizes and incorporate a control panel housing for standard & custom apertures together with power outlets.

High quality monitor arm is fully adjustable, desk top has generous room for keyboard and visualiser (if required). All are available in 1000, 1250 & 1500mm widths, 750mm deep with a choice of wood effect finishes.

In addition to the standard units offered we are able to customise for a wide range of requirements plus colour options and branding.

- Customised control housing options.
- Secure front and rear installation access.
- Lockable, with key alike options.
- Concealed castors, plus levelling feet.
- 19" 16U rack supplied as standard.
- Quality wood finish, 36mm thick work surface.
- Includes articulated screen arm as standard.

Please note: prices quoted are ex-works as this unit is despatched by dedicated courier or may be collected.



Example 1000mm Desk Top Canterbury™ Lectern (UFCL10)



Part Code & Description	Cost £ (Exc. VAT)	Dimensions (H x W x Dmm)	Weight	Lectern Cabinet Colour Options	Desk Top Colour Options
UFCL10   1000mm Desk Top Canterbury™ Lectern	2810.60	987 x 1000 x 750	variable	■ □	Oak, Beech, Grey, Black, White
UFCL12   1200mm Desk Top Canterbury™ Lectern	2890.30	987 x 1200 x 750	variable	■ □	Oak, Beech, Grey, Black, White
UFCL15   1500mm Desk Top Canterbury™ Lectern	3020.10	987 x 1500 x 750	variable	■ □	Oak, Beech, Grey, Black, White

## Wall-Mounted Control Desks

The Presenter™ is ideal for small lecture theatres or anywhere where space is limited. Folding work surface is ideal for laptop, notes etc. Unit is designed to be functional yet compact, with many control panel options.

Lockable cabinet (with key alike options) is provided for a PC with access to PC ports and power through the side of the unit. A 3U rack strip is also built in. Options include standard UK two gang aperture, plus any other control panel features required.

Please enquire to discuss requirements.

Please note: prices quoted are ex-works as this unit is despatched by dedicated courier or may be collected.



Example Wall Mounted Presenter™ Desk (UFPL08)

Part Code & Description	Cost £ (Exc. VAT)	Dimensions (H x W x Dmm)	Weight	Lectern Cabinet Colour Options	Work Surface Colour Options
UFPL08   Wall Mounted Presenter™ Desk	1130.80	796 x 800 x 605	variable	■ □	■ □





## The Lecturer's Teaching Aid Desk

### The Principal™ Series

Provides lecturer's with a central desk facility to control AV lecture content, screen or projector video sources, audio, lighting levels and more. Cabinets have 19" removable 12U racks. The desk powers up and down for standing or seated operation using the manual switch or remote fob.

- 19" removable 12U racks to allow for pre-installation.
- Full cable management, accommodating bulky connectors.
- Motorised desk top in a range of widths and finishes.
- Screen mount has left/right or multi-screen options.
- Control housing has standard and custom apertures.
- Quick release doors for ease of installation.
- Generous desk top space for visualiser if required.
- Castor mobile for access through standard doorways.
- Optional extras include illuminated branding and more.
- Rapid turnaround.



Example 1850mm Desk Top Principal™ Desk (UFPD18)



To order, choose from the models listed below and select finish options (right). Please include preference for left or right monitor arm and control panel housing requirements.

Please note: prices quoted are ex-works as this unit is despatched by dedicated courier or may be collected.

Part Code & Description	Cost £ (Exc. VAT)	Dimensions (H x W x Dmm)	Weight	Desk Cabinet Colour Options	Desk Top Colour Options
UFPD15   1550mm Desk Top Principal™ Desk	POA	884-1544 x 1550 x 700	variable	■ □	Oak, Beech, Grey, Black, White
UFPD18   1850mm Desk Top Principal™ Desk	POA	884-1544 x 1850 x 700	variable	■ □	Oak, Beech, Grey, Black, White
UFPD24   2400mm Desk Top Principal™ Desk	POA	884-1544 x 2400 x 700	variable	■ □	Oak, Beech, Grey, Black, White

### The Mentor™ Series

Provides lecturer's with a central desk facility to control AV lecture content, screen or projector video sources, audio, lighting levels and more.

- Hinged desk top provides easy access to AV devices.
- 19" removable 12U racks with additional 1U rack featured in the desk leg.
- Full cable management with lockable storage.
- Concealed castors plus levelling feet.
- Neat quick release door mechanism.
- Optional extras include illuminated branding & more.



Example 1300mm Desk Top Mentor™ Desk (UFMD13)

To order, choose finish options (below & above). Please include preference for left or right monitor arm and control panel housing requirements.

Please note: prices quoted are ex-works as this unit is despatched by dedicated courier or may be collected.

Part Code & Description	Cost £ (Exc. VAT)	Dimensions (H x W x Dmm)	Weight	Desk Cabinet Colour Options	Desk Top Colour Options
UFMD13   1300mm Desk Top Mentor™ Desk	POA	790-1196 x 1300 x 700	variable	■ □	Oak, Beech, Grey, Black, White

## Rack & Screen Cabinets

Our AV Media Cabinets provide secure, lockable storage for a wide range of electronics. Available in a variety of styles and sizes, these solutions offer integrators a wide flexibility of choice to meet the requirements of end users. Single and twin cabinets have ready provision to accept most assemblies (M1X1 or M2X1).

Please note: prices quoted are ex-works as this unit is despatched by dedicated courier or may be collected.

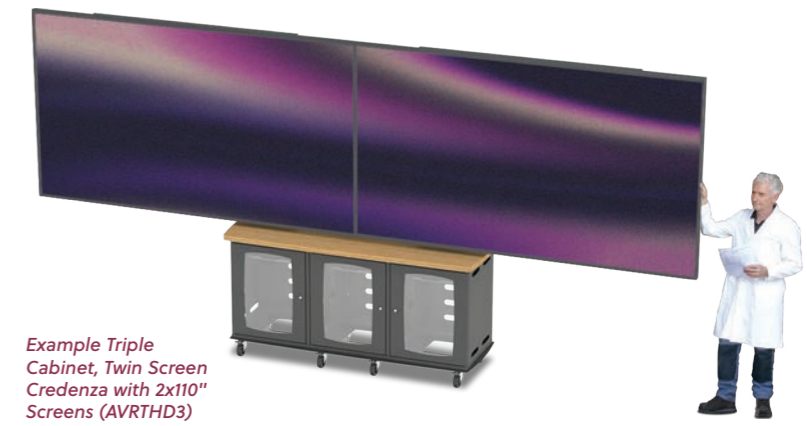

Example Triple Cabinet, Twin Screen Credenza with 2x110" Screens (AVRTHD3)

### Single & Twin Cabinet Options

- 19" rack mounting as standard.
- Additional shelves available (below).
- Available in 442mm or 642mm depths.
- Single and twin screen mast assemblies.
- Custom versions available on request.



Part Code & Description	Cost £ (Exc. VAT)	Dimensions (H x W x Dmm)	Weight	Screen Size	VESA Fixing (Min / Max)	Weight Cap.	Colour
AVR5   Standard Single Rack Cabinet (442mm rack depth)	449.20	890 x 580 x 565	47.2kg	n/a	n/a	n/a	■
AVR7   Extended Single Rack Cabinet (642mm rack depth)	468.50	890 x 580 x 765	61.0kg	n/a	n/a	n/a	■
AVR9   Oval Style Single Rack Cabinet (442mm rack depth)	496.50	890 x 775 x 590	58.3kg	n/a	n/a	n/a	■
M1X1   Single Screen Mast Assembly (Including mount)	304.55	1546 x 765 x 172	18.6kg	33 - 57"	200x200 / 600x400	40kg	■
AVR75   Standard Twin Rack Cabinet (442mm rack depth)	946.30	896 x 1200 x 640	88.3kg	n/a	n/a	n/a	■
AVR77   Extended Twin Rack Cabinet (642mm rack depth)	984.90	896 x 1200 x 840	107.2kg	n/a	n/a	n/a	■
M2X1   Twin Screen Mast Assembly (Including mount)	647.20	1546 x variable x 172	variable	33 - 57"	200x200 / 600x400	35kg*	■

\*max weight per screen

### Triple Cabinet Options

- Incorporates twin screen as standard.
- Includes cabinet, mast assemblies, screen mounts and 3x12U racks.
- 19" rack mounting as standard.
- Additional shelves available (below).
- Custom versions available on request.

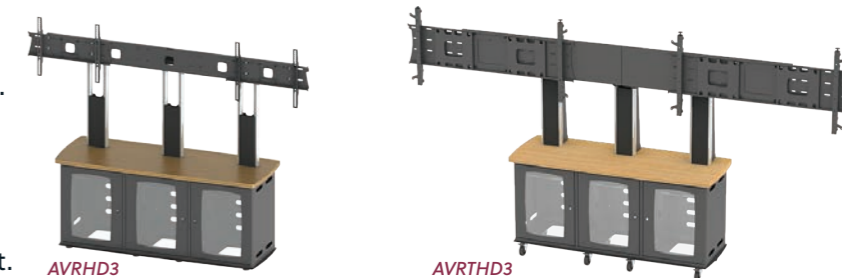

Part Code & Description	Cost £ (Exc. VAT)	Dimensions (H x W x Dmm)	Weight	Screen Size	VESA Fixing (Min / Max)	Weight Capacity	Colour
AVRHD3   Triple Cabinet, Twin Screen Credenza (up to 75")	4085.20	variable	variable	57 - 75"	300x300 / 1000x600	60kg*	■
AVRTHD3   Triple Cabinet, Twin Screen Credenza (up to 110")	POA	variable	variable	76 - 110"	400x600 / 1500x1000	100kg*	■

\*max weight per screen

### Universal Shelves & Racks

Product Image	Part Code & Description	Cost £ (Exc. VAT)	Dimensions (H x W x Dmm)	Weight	Weight Capacity	Colour
	VR500   430mm Deep Shelf (for AVR5 / AVR9 / AVR75)	51.50	20 x 493 x 430	3.0kg	10kg	■
	VR700   630mm Deep Shelf (for AVR7 / AVR77)	52.75	20 x 493 x 630	4.3kg	10kg	■
	VR300   1U Rack (445w x 345d mm)	42.96	44 x 482 x 349	1.9kg	10kg	■
	RF6U19   6U Rack (400mm deep)	300.00	335 x 513 x 530	4.9kg	10kg	■
	RF8U19   8U Rack (400mm deep)	320.00	424 x 513 x 530	5.1kg	10kg	■
	RF10U19   10U Rack (400mm deep)	340.00	513 x 513 x 400	5.4kg	10kg	■



## The Preferred Method of Projector Mounting

All our PSU™ mounts are designed to align accurately with the projector mounting holes and take account of cooling or lamp access needs. This is what makes our projector suspension units the preferred method of projector mounting.

The cradle versions (PSC) offer an alternative method of projector mounting, either to meet a projector's optical needs or to give protection to projectors when used in location-to-location or hire circumstances.

All PSU™ mounts are now available as micro adjustable versions with 2 axis and precision adjustment for level & tilt. Call to discuss.

Custom versions available including mounting downward/upward, multiple projectors, 3D rigs and more. Get in touch with our special projects team for your next installation.

*Please state projector make and model when ordering. Images are illustrative and final product may vary slightly from what is shown. Call for any advice or assistance.*



Part Code & Description	Cost £ (Exc. VAT)	Dimensions (H x W x Dmm)	Weight	Weight Capacity	Colour
PSU1   Standard Projector Suspension Unit	138.00	variable	variable	40kg	■ □
PSU2   Heavy Duty Projector Suspension Unit	170.00	variable	variable	70kg	■ □
PSC   Cradle Style Projector Suspension Unit	172.00	variable	variable	40kg	■ □
VSU   Vertical Aspect Projector Suspension Unit	165.00	variable	variable	40kg	■ □
PPSU   Portrait Projector Suspension Unit	271.20	variable	variable	40kg	■ □
PSM   Micro-Adjustable Style Projector Suspension Unit	206.80	variable	variable	40kg	■ □

### Accessories

Product Image	Part Code & Description	Cost £ (Exc. VAT)	Dimensions (H x W x Dmm)	Weight	Weight Cap.	Colour
	TD1   Trim Disc (Ceiling Finisher - see page 27)	8.65	25 x 90 x 90	0.04kg	n/a	■ □
	TDRF   Retro Fit Trim Disc (Post-Install - see page 27)	14.75	variable	variable	n/a	■ □
	TDB1   Blanking Disc (Blanks Ceiling Holes - see page 27)	8.65	16 x 90 x 90	0.08kg	n/a	■ □

## Anti-Theft Projector Enclosures

Aid security of your projector with our Guardbox® range. Gives added reassurance particularly where projectors are used in public areas, education, sports facilities and more. Five sizes available covering a wide range of projectors. Constructed from heavy gauge steel and incorporating many innovative features.

Each Guardbox® incorporates our unique anti-hacksaw bar system which allows variable positioning to ensure lens clearance for any make and model of projects. Adjustable levelling bars to ensure perfect image positioning are incorporated in the base of each Guardbox®.

### NEW! Single Column Trolley Guardbox®

Use when projectors need to move from room to room or to secure in storage. Alternative base types and different height options available.

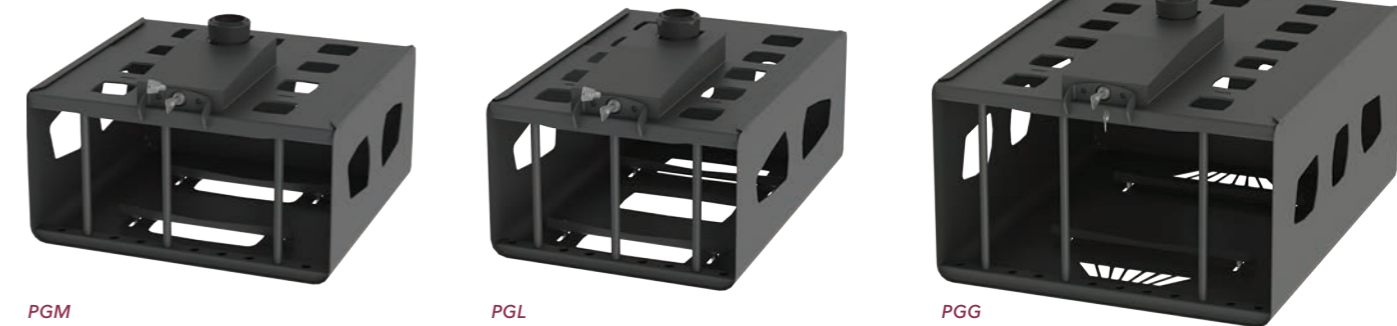

Product Image	Part Code & Description	Cost £ (Exc. VAT)	Dimensions (H x W x Dmm)	Weight	Weight Capacity	Colour
	PGX   180h x 390w x 320d mm Projector Guardbox®	279.80	330 x 405 x 375	12.4kg	n/a	■ □
	PGS   180h x 400w x 430d mm Projector Guardbox®	282.60	330 x 405 x 475	14.4kg	n/a	■ □
	PGM   180h x 490w x 420d mm Projector Guardbox®	341.70	330 x 500 x 475	17.2kg	n/a	■ □
	PGL   180h x 400w x 520d mm Projector Guardbox®	343.50	330 x 405 x 575	14.9kg	n/a	■ □
	PGG   250h x 560w x 620d mm Projector Guardbox®	352.60	411 x 565 x 680	27.9kg	n/a	■ □
	PGW   250h x 600w x 550d mm Projector Guardbox®	350.20	411 x 605 x 613	27.5kg	n/a	■ □
	1000C   1000mm Ceiling Suspension Chrome Column	32.50	1000 x 50.8 x 50.8	1.8kg	n/a	●
	2000C   2000mm Ceiling Suspension Chrome Column	65.00	2000 x 50.8 x 50.8	3.7kg	n/a	●
	3000C   3000mm Ceiling Suspension Chrome Column	97.50	3000 x 50.8 x 50.8	5.5kg	n/a	●
	CP1   Standard Ceiling Plate (See page 28 for more info)	28.70	121 x 160 x 160	1.1kg	60kg	■ □
	CP2   Large Ceiling Plate (See page 28 for more info)	42.90	122 x 272 x 272	2.7kg	120kg	■ □
	CPSC1   Locking Ceiling Plate (Compatible with CP1 only)	45.40	82 x 181 x 181	1.1kg	n/a	■ □

### Accessories

Part Code & Description	Cost £ (Exc. VAT)	Dimensions (H x W x Dmm)	Weight	Weight Capacity	Colour
TLK   Taglock Kit (Additional Security for Guardbox® Range)	25.10	n/a	0.05kg	n/a	n/a
TDB1   Blanking Disc (Blanks Ceiling Holes - see page 28)	8.65	16 x 90 x 90	0.08kg	n/a	■ □



## Award Winning, Installer Friendly Projector Mounts

Over 20 years of award winning design with over 400,000 Gyrolock® mounts sold - the Gyrolock® range is the industry standard for AV integrators when mounting projectors up to 20kg.

- Wide range of styles and suspension lengths to suit headroom specifications in your installation.
- Column suspension versions allow for increased compatibility with other UNICOL products.
- Over 20 years of award winning design.
- Full tilt and turn adjustment for easy set up.
- Available in Sinterflex Black as standard with Sinterflex White as a no cost option.

These products are the subject of UK and USA design rights. UK Registered Design 3011575. UK Trade Mark 2244062. US Patent 10/049390. EU Registered Design 00221072-0001 (GAPU Universal Adapter Plate)



### Universal & Dedicated Mount Options

Both mounting options are available to ensure you get the best fit for your projector. Universal mounts offer a weight capacity of 12kg, whilst dedicated mounts cater for projectors up to 20kg.

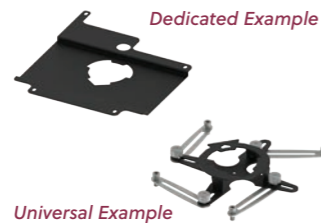

Example Dedicated 230-700mm Length Projector Mount (GK2-GAP)

### Trilok® Universal & Dedicated Docking System

The Trilok® docking system uses a standardised 'bayonet style' fitting to carry dedicated projector mounting plates made specifically to fit each make & model of projector (universal version also listed). The docking system allows easy projector set up, removal for routine maintenance and for future model change.

- Full tilt and turn adjustment for easy set up.
- Telescopic style for use in any headroom situation.
- Parts & Accessories available on page 51 (right).

Please state projector make and model when ordering. Images are illustrative and final product may vary slightly from what is shown. Call for any advice or assistance.

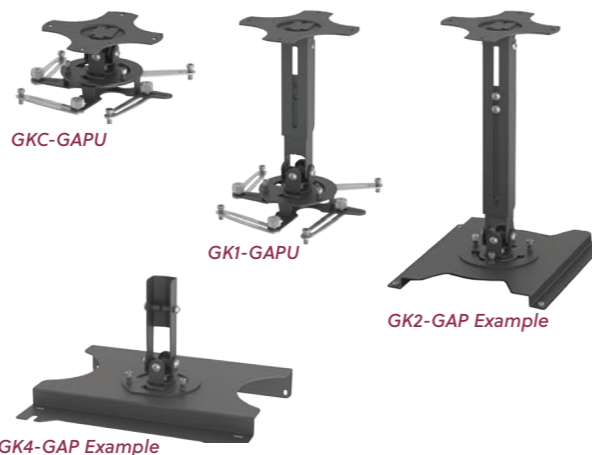

Part Code & Description	Cost £ (Exc. VAT)	Dimensions (H x W x Dmm)	Weight	Weight Cap.	Col.
GKC-GAP   Dedicated Close Ceiling Mount (Dedicated Trilok® Adapter (GAP))	135.80	variable	variable	20kg	■ □
GKC-GAPU   Universal Close Ceiling Mount (Universal Trilok® Adapter (GAPU))	135.80	90 x 220-430 x 220-430	1.4kg	12kg	■ □
GK1-GAP   Dedicated 230-300mm Length Mount (Dedicated Trilok® Adapter (GAP))	149.60	variable	variable	20kg	■ □
GK1-GAPU   Universal 230-300mm Length Mount (Universal Trilok® Adapter (GAPU))	149.60	230-300 x 220-430 x 220-430	1.9kg	12kg	■ □
GK2-GAP   Dedicated 230-700mm Length Mount (Dedicated Trilok® Adapter (GAP))	167.80	variable	variable	20kg	■ □
GK2-GAPU   Universal 230-700mm Length Mount (Universal Trilok® Adapter (GAPU))	167.80	230-700 x 220-430 x 220-430	2.8kg	12kg	■ □
GK4-GAP   Dedicated Column Suspension Mount (Dedicated Trilok® Adapter (GAP))	129.20	variable	variable	20kg	■ □
GK4-GAPU   Universal Column Suspension Mount (Universal Trilok® Adapter (GAPU))	129.20	188 x 220-430 x 220-430	1.2kg	12kg	■ □

### Gyrolock® Universal Docking System

These universal mounts offer a wide range of adjustment not only to cover widely differing projector screw fixing centres but also allow clearance for contour variations often found in projector design. A universal screw pack to cover most projectors is included.

- Telescopic style for use in any headroom situation.
- Parts & Accessories available below.

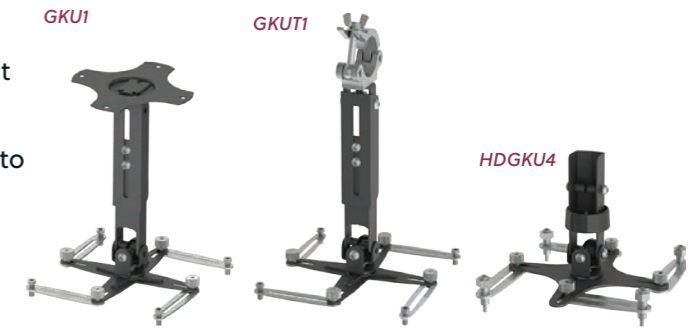

Please state projector make and model when ordering.

Part Code & Description	Cost £ (Exc. VAT)	Dimensions (H x W x Dmm)	Weight	Weight Cap.	Colour
GK0   Camera Screw 230-300mm Length Mount	66.90	230-300 x 183 x 183	1.0kg	12kg	■ □
GKU1   Universal 230-300mm Length Mount (Incorporated GAPU)	89.80	230-300 x 220-430 x 220-430	1.5kg	12kg	■ □
GKU2   Universal 230-700mm Length Mount (Incorporated GAPU)	108.10	230-700 x 220-430 x 220-430	2.3kg	12kg	■ □
GKUX   Universal Compact Close Ceiling Mount (Incorporated GAPU)	69.10	134 x 220-430 x 220-430	0.9kg	12kg	■ □
GKU3   Universal 700-1200mm Length Mount (Incorporated GAPU)	114.90	700-1200 x 220-430 x 220-430	3.8kg	12kg	■ □
GKUT1   Truss Clamp Style Universal 230-300mm Mount (Incorporated GAPU)	109.80	230-300 x 220-430 x 220-430	1.7kg	12kg	■ □
GKUT3   Truss Clamp Style Universal 700-1200mm Mount (Incorporated GAPU)	134.80	230-700 x 220-430 x 220-430	3.9kg	12kg	■ □
GKU4   Column Suspension Mount (Incorporated GAPU)	69.50	169 x 220-430 x 220-430	0.9kg	12kg	■ □
HDGKU4   Heavy Duty Column Suspension Mount (Incorporated GAPU)	138.00	169 x 220-430 x 220-430	1.3kg	30kg	■ □

### Trade Packs

- Combines all the necessary components for a typical ceiling suspended projector installation.
- Incorporates a universal GKU4 mount as standard.
- Offer a wide range of adjustment to accommodate different screw fixing centres and contour variations.
- Utilises modular connectivity with other UNICOL parts.
- Other column lengths available upon request.

Please state projector make and model when ordering.



Part Code & Description	Cost £ (Exc. VAT)	Dimensions (H x W x Dmm)	Weight	Weight Cap.	Col.
KPR15CB   Universal 500mm Column Suspension Projector Trade Pack (Includes GKU4)	110.00	630 x 220-430 x 220-430	2.9kg	12kg	■ □
KPR110CB   Universal 1000mm Column Suspension Projector Trade Pack (Includes GKU4)	130.00	1130 x 220-430 x 220-430	3.8kg	12kg	■ □
KPR120CB   Universal 2000mm Column Suspension Projector Trade Pack (Includes GKU4)	160.00	2130 x 220-430 x 220-430	5.6kg	12kg	■ □
KPR130CB   Universal 3000mm Column Suspension Projector Trade Pack (Includes GKU4)	190.00	3130 x 220-430 x 220-430	7.5kg	12kg	■ □

### Accessories

Product Image	Part Code & Description	Cost £ (Exc. VAT)	Dimensions (H x W x Dmm)	Weight	Weight Capacity	Colour
	GAP   Dedicated Gyrolock® Adapter Plate	44.30	variable	variable	20kg	■ □
	GAPU   Universal Gyrolock® Adapter Plate	44.30	27 x 220-430 x 220-430	0.5kg	12kg	■ □
	GKTD   Gyrolock® Trim Disc	8.65	31 x 90 x 90	0.06kg	n/a	■ □
	GT40   400mm Tetherloc Gyrolock® Anti-Theft Kit	78.80	444 x 154 x 37	0.8kg	n/a	■
	GT80   800mm Tetherloc Gyrolock® Anti-Theft Kit	84.80	844 x 154 x 37	1.0kg	n/a	■
	GT130   1300mm Tetherloc Gyrolock® Anti-Theft Kit	91.50	1344 x 154 x 37	1.3kg	n/a	■



## The Original UNICOL System

These single column solutions have supported Education and the AV industry for over 60 years.



Part Code & Description	Cost £ (Exc. VAT)	Dimensions (H x W x Dmm)	Weight	Weight Capacity	Colour
SS/45/PA   Flat Platform Projector Trolley	177.04	1314 x 450 x 550	10.9kg	35kg	■
MS/24/PB   General Purpose, Flat Platform Trolley	157.78	787 x 460 x 460	8.1kg	35kg	■
MG/45/PE   Fixed Angle Lectern Stand	187.65	1320 x 460 x 460	7.9kg	10kg	■
LS/2533/PC   Flat Platform, Telescopic Trolley	226.24	730-948 x 650 x 550	11.5kg	35kg	■
LS/3350/TGA   Tilting Platform, Telescopic Trolley	262.04	935-1375 x 650 x 550	12.1kg	35kg	■
T1B/24/PB   Flat Platform Equipment Trolley	184.79	870 x 767 x 645	15.0kg	35kg	■
CS1000   Telescopic Camera Stand	465.45	1623 x 767 x 647	23.9kg	6kg	■
CS2000   Studio Camera Stand	465.45	2135 x 767 x 647	26.7kg	6kg	■

## Configure Your Own Single Column Solution Below

Product Image	Part Code & Description	Cost £ (Exc. VAT)	Dimensions (H x W x Dmm)	Weight	Weight Cap.	Colour
	PA   300w x 450d mm Flat Platform	74.91	151 x 310 x 460	2.9kg	35kg	■
	PB   450w x 450d mm Flat Platform	86.57	151 x 460 x 460	3.7kg	35kg	■
	PC   450w x 550d mm Flat Platform	97.95	151 x 460 x 560	4.3kg	35kg	■
	PE   450w x 450d mm 15° Fixed Angle Lectern Platform	98.67	220 x 460 x 460	3.0kg	10kg	■
	TGA   300w x 450d mm Adjustable Tilting (0-10°) Platform	115.45	191 x 310 x 460	3.3kg	35kg	■
	TGB   450w x 450d mm Adjustable Tilting (0-10°) Platform	127.99	191 x 460 x 460	4.1kg	35kg	■
	TGC   450w x 550d mm Adjustable Tilting (0-10°) Platform	139.15	191 x 460 x 560	4.7kg	35kg	■
	16   410mm Standard Chrome Column	13.45	410 x 50.8 x 50.8	0.8kg	n/a	●
	24   610mm Standard Chrome Column	18.85	610 x 50.8 x 50.8	1.1kg	n/a	●
	30   760mm Standard Chrome Column	25.05	760 x 50.8 x 50.8	1.4kg	n/a	●
	36   900mm Standard Chrome Column	40.50	900 x 50.8 x 50.8	1.7kg	n/a	●
	45   1140mm Standard Chrome Column	37.50	1140 x 50.8 x 50.8	2.1kg	n/a	●
	2533   640 - 840mm Telescopic Column	60.80	569-787 x 70 x 70	2.8kg	n/a	■
	3350   840 - 1280mm Telescopic Column	79.10	762-1202 x 70 x 70	4.4kg	n/a	■
	AP   300w x 300d mm Accessory Shelf	82.45	113 x 310 x 350	2.4kg	15kg	■
	AD   400w x 400d mm Accessory Shelf	92.62	113 x 410 x 450	3.2kg	15kg	■
	MS   400w x 400d mm Trolley Base	52.36	183 x 410 x 410	3.2kg	60kg	■
	MG   400w x 400d mm Stand Base	51.48	156 x 410 x 410	2.8kg	60kg	■
	SS   450w x 550d mm Trolley Base with Jacking Feet	64.63	183 x 450 x 550	3.9kg	60kg	■
	LS   550w x 650d mm Trolley Base with Jacking Feet	67.49	183 x 550 x 650	4.4kg	60kg	■
	T1B   Heavy Duty Trolley Base with 10cm Rubber Tyre Castors	79.37	277 x 767 x 645	10.1kg	80kg	■

	<b>Allen Key(s)</b> A staple for any AV integrator. Standard 3/16th size to fit grub screws & through bolts. <b>AK316   £0.70 exc. VAT</b>		<b>Grub Screw</b> A spare grub screw that is compatible with most UNICOL products. <b>GS38F   £0.25 exc. VAT</b>
	<b>Hand Wheel</b> Spare individual hand wheels. Ideal for any AV installers tool kit. <b>HW38F   £1.05 exc. VAT</b>		<b>Safety Through Bolt</b> Spare safety through bolt for ceiling suspended solutions. <b>TB38F   £1.15 exc. VAT</b>
	<b>Socket Cap</b> Provide a tighter fit when combining adapters, mounts & more to UNICOL's columns. <b>SC   £3.50 exc. VAT</b>		<b>Replacement Lock &amp; Key</b> Typically used in Guardbox, Rhobus, AV Media Cabinet and Locking Cabinet ranges. <b>LK   £25.10 exc. VAT</b>
	<b>Column Drilling Jig</b> Trim columns down and drill through-bolt holes in the right place to ensure that your modular installation fits together perfectly. <b>CDJ1   £42.10 exc. VAT</b>		<b>Screen Security Kit</b> Protect your screen by utilising the 2200mm tough steel cable system with special fittings that shield access to fixing screws. <b>PSK   £89.97 exc. VAT</b>
	<b>Locking Ceiling Plate</b> Designed to fit securely around the CP1 Standard Ceiling Plate, to shield the fixings and prevents unauthorised access. <b>CPSC1   £45.40 exc. VAT</b>		<b>Remote Wall Holders</b> Reflects the remotes infrared beam direct to the projector or screen. No need to hard wire! <b>RGHW (Universal) £58.60 exc. VAT</b> <b>RGH1W (Dedicated) £65.00 exc. VAT</b>
	<b>Video Conference Camera Wall Shelves</b> <b>350w x 250d Metal Shelf</b> WBVC (up to 20kg) <b>£71.30 exc. VAT</b> <b>500w x 400d Glass Shelf</b> WBVG (up to 20kg) <b>£86.40 exc. VAT</b> <b>780w x 390d Glass Shelf</b> WBVG1 (up to 20kg) <b>£108.90 exc. VAT</b>		<b>Columns</b> In standard chrome finish and stainless steel. Also available in colour finishes to special order. In addition to the sizes listed we can supply non-standard lengths.  For ceiling suspension, add 'C' to end of order code. Please note that Safety 'through-bolt' holes must be specified if used for suspension applications.
	<b>Spray Paint</b> 400ml touch-up paint cans. <b>SPB (Sinterflex Black) £35.60 exc. VAT</b> <b>SPW (Sinterflex White) £35.60 exc. VAT</b> <b>SPS (Diamond Silver) £35.60 exc. VAT</b>		<b>Chrome</b> <b>500 (500mm) £16.25 exc. VAT</b> <b>1000 (1000mm) £32.50 exc. VAT</b> <b>1500 (1500mm) £48.75 exc. VAT</b> <b>2000 (2000mm) £65.00 exc. VAT</b> <b>2500 (2500mm) £81.25 exc. VAT</b> <b>3000 (3000mm) £97.50 exc. VAT</b>
	<b>5cm Castors (Orbit)</b> <b>C05X4 (Set of 4) £14.00 exc. VAT</b> <b>7.5cm Castors (2 Plain, 2 Braked)</b> <b>C074X4 (Set of 4) £28.20 exc. VAT</b> <b>10cm Castors (Plain)</b> <b>C10X4 (Set of 4) £34.60 exc. VAT</b> <b>10cm HD Castors (Braked)*</b> <b>BC10X4 (Set of 4) £94.00 exc. VAT</b>		<b>Stainless Steel</b> <b>500SS (500mm) £31.45 exc. VAT</b> <b>1000SS (1000mm) £62.85 exc. VAT</b> <b>1500SS (1500mm) £124.30 exc. VAT</b> <b>2000SS (2000mm) £155.70 exc. VAT</b> <b>3000SS (3000mm) £218.55 exc. VAT</b>

\*Please note: Our 10cm Heavy Duty castors (BC104) are bolt fixed for added strength and to prevent swivel as well as rotation of the wheel, they are intentionally not interchangeable with our 10cm (C104) castors.



Supporting *AV* Since 1963

+44 (0)1865 767676

sales@unicol.com

unicol.com

UNICOL Engineering, Green Road, Oxford, OX3 8EU



LED Roller-Trak™  
pages 41-42

Outdoor Housings  
page 38

Accession™ Service  
Wall Mounts  
(ASMW1) - page 24

Gyrolock® Projector Mounts  
(GKU1) - pages 52-53



Mentor Lecturer's Desk  
(UFMD13) - page 48